

Versatile, High-Performance, Turn-key

Hyperspectral Scanning Solution



The ClydeHSI SC-C80 Hyperspectral Scanning Solution is a complete, turnkey hyperspectral solution that includes: spectral camera, scanning stage, interchangeable sample trays, lighting system, focus target, reflectance standard, data acquisition, viewing and analysis software.

ClydeHSI SC-C80 systems have a 220mm wide conveyor belt and can acquire high resolution spectral images in seconds. The system can operate up to two spectral cameras with simultaneous data acquisition, and is fully compatible with all ClydeHSI hyperspectral cameras and software.

Capable of making hundreds of measurements per day under extremely stable and repeatable conditions, SC-C80 datasets are ideal for model creation for ultra-high speed, real-time production line sorting/grading applications.

Other key features: auto-focus and auto-product height adjustment, fully integrated lighting stage, speed sensors for automatic frame rate calculation for square pixels.

Key Features:

Auto-focus of Spectral Cameras

Auto-exposure Setting

Auto-square-pixel Facility

Simultaneous Dual Camera Acquisition

Integrated Illumination System

Multiple Conveyor Belt Sizes

Feed-in/out Option

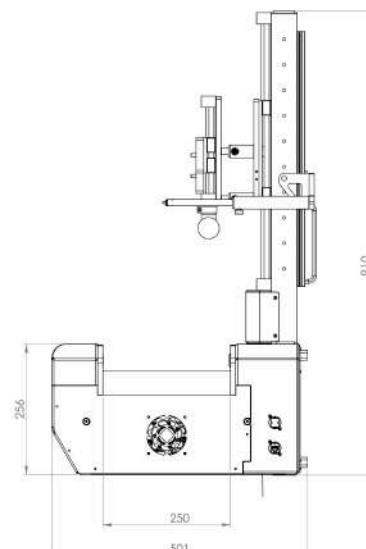
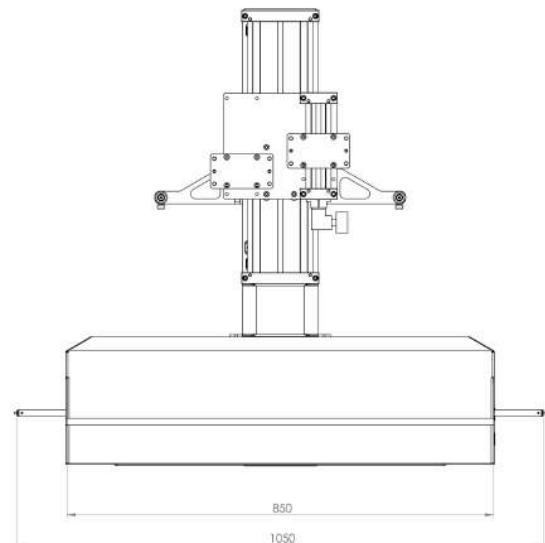

Scanning Stage Technical Specifications

Parameter	Value	Units	Comment
Spectral Range	400-2500	nm	Raman options available: consult ClydeHSI
Effective Belt Width	240	mm	Allows 10mm clearance on either side of sample
Scan Speed	0.2 to 300	mm/s	Automatically synchronised with camera frame rate by software
Camera Stand-off Distance	Up to 700	mm	Fully motorised adjustment via software
Feed In/Out	Optional gravity roller system	-	Consult ClydeHSI
Sensors	Speed adjustment for square pixels	-	Automatic
Dimensions	800 x 300 x 1000	mm	L x W x H
Weight	90	kg	

Example System Configuration

Comprising of the following:

- SC-C80 Conveyor Belt Scanner
- VNIR-HR 400 to 1000nm, hyperspectral camera
- NIR-HR+ 950 to 1700nm hyperspectral camera
- Broad-band illumination
- Fore Objective Lens Kit
- Setup, focus, and calibration tiles
- Workstation computer
- Acquisition, visualisation, and analysis software
- Installation and application support.

Optional Accessories

Comprising of the following:

- Auto-product height adjustment
- Machine vision systems for production line use
- Model creation for ultra-high speed, real-time production line sorting/grading applications
- SWIR-Series hyperspectral camera (1000-2500 nm)
- UV (300-400 nm) hyperspectral camera
- Raman hyperspectral camera and laser line illuminators
- LED and super continuum laser illuminators

