



SC-PT SERIES

Portable, Turn-key, Pan and Tilt

Hyperspectral Scanning Systems



ClydeHSI SC-PT Pan and Tilt Hyperspectral Scanning Systems are complete, transportable, hyperspectral scanning systems, designed for scanning objects and large scenes in hard to reach places at high speed and high resolution. Operates in both single and dual-camera modes within the spectral range from UV to SWIR (300-2500nm). The system is tripod mountable and is supplied with an airline check-in friendly case, and includes spectral camera(s), SC-PT Series scanning system, illumination system, high performance computer, and all data acquisition, display, and analysis software, plus unlimited technical support from ClydeHSI.

All SC-PT Series scanners have auto-exposure, auto-frame rate and scan motion correction, as well as laser target finding systems and time-of-flight sensors for accurate region-of-interest selection across full measurement area.

Key Features:

Single or Dual Camera Operation

Tripod Mountable

Battery Pack Option for Field Use

Laser Crosshair for Accurate ROI Setting

Entire System in One Airline Check-in Friendly Case

Automatic Spherical-to-rectangular Coordinate Transformation

Auto-exposure Setting

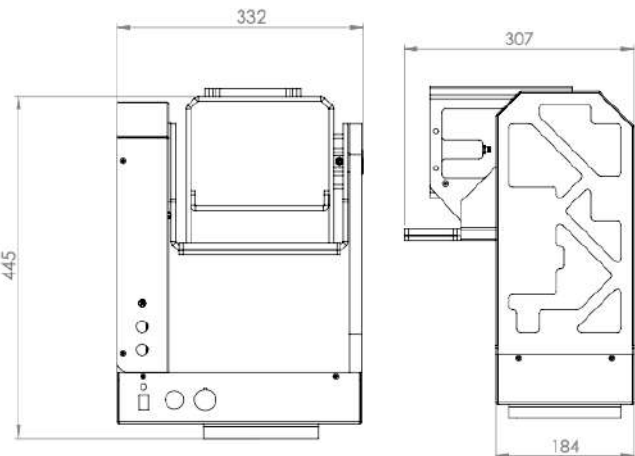

Front View

Side View

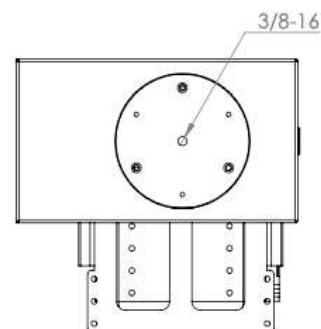

Bottom View and Mounting

Scanning Stage Technical Specifications

Parameter	Value	Units	Comment
Scan Movement	Pan and tilt		Multi-modal operation with spectral correction and multi-strip mosaic imaging for large area high resolution scans
Pan Angle	360	deg	
Pan Resolution	0.01	deg	
Tilt Angle	±30	deg	
Tilt Resolution	0.01	deg	
ROI Setting	Laser crosshair assisted		
Stand-off Distance Measurement	Manual or time-of-flight assisted		Time-of-flight sensor option
Payload	25	kg	Accommodates multiple spectral cameras with simultaneous data acquisition, and illumination modules
System Weight	15	kg	
Power Supply	85-264 50/60	V AC Hz	

Example System Configuration

- SC-PT Series Scan Module
- VNIR-HR 400 to 1000nm, hyperspectral camera
- NIR-HR+ 950 to 1700nm hyperspectral camera
- Free wavelength selection within spectral range of each camera
- Broad-band (400-2500nm) illumination system
- Fore Objective Lens Kit
- Setup, focus, and calibration (reflectance) tiles
- Laser target finding system for accurate ROI setting
- Workstation computer
- Acquisition, visualisation, and analysis software
- Installation and testing by ClydeHSI engineer
- Application support and data processing help

Optional Accessories

- Photographic Tripod
- Photogrammetry (16 Mpix to 400 Mpix camera options)
- NIR Reflectography
- HSI UV (320-500nm) and UV illuminators
- HSI Raman and laser line illuminators
- SWIR-Series 960-2500nm Hyperspectral Camera
- LED and super-continuum laser illuminators
- Database server and software
- Downwelling irradiance sensor

