

Product Data Sheet

Refrigerant Dryer DFLO-ES 66 to DFLO-ES 600 (-W) with energy saving management

Version: 1.9.3

Author: Karsten Unger

Datum: 21.02.2022

Field of application

Refrigeration dryers of the DFLO-ES series are designed for drying compressed air flows up to 16 bar (g) to pressure dew points up to +3°C for compressed air without aggressive substances.



Function

The incoming compressed air passes enters into an air/air heat exchanger and become pre-cooled. The pre-cooling effects in counter-flow direction to the out coming compressed air and works without any demand of energy. Further cooling effects in the patented air/refrigerant/glycol heat exchanger which is cooled by a refrigerant circuit. During the cooling process, humidity condenses as water and will be discharged automatically. The excessive cooling power becomes saved in the glycol circuit and provides cooling of compressed air in partial flow conditions whilst the refrigerant compressor remains in stand-by. The outlet flow will heated up in counter-flow direction to the incoming compressed air.

All models from size 150 are also available as water-cooled versions, incorporating also a chill water control valve.

Product data sheet

Refrigerant Dryer DFLO...ES

Features

All models are equipped with an automatic compressor deactivation, glycol circuit (already filled), level controlled condensate drain, dewpoint indicator, solid metal frame housing and potential free contacts for operating and fault messages.

The refrigeration dryers comply with the requirements of the Pressure Equipment Directive 2014/68/EU as well as with the Machinery Directive 2006/42/EC and have the corresponding CE marking.

The air-to-air heat exchanger, the evaporator and the demister condensate separator made from aluminium are comprised in one module. This results in a compact, rugged and energy-saving design. The cooling registers are designed such that the condensate is discharged on the entire cooling path (in conventional refrigeration dryers the condensate is only discharged at the end of the cooling circuit). The generously designed air circuit causes low flow velocities and therefore results in very good condensate separation and very low pressure losses.

Energy reduction mode

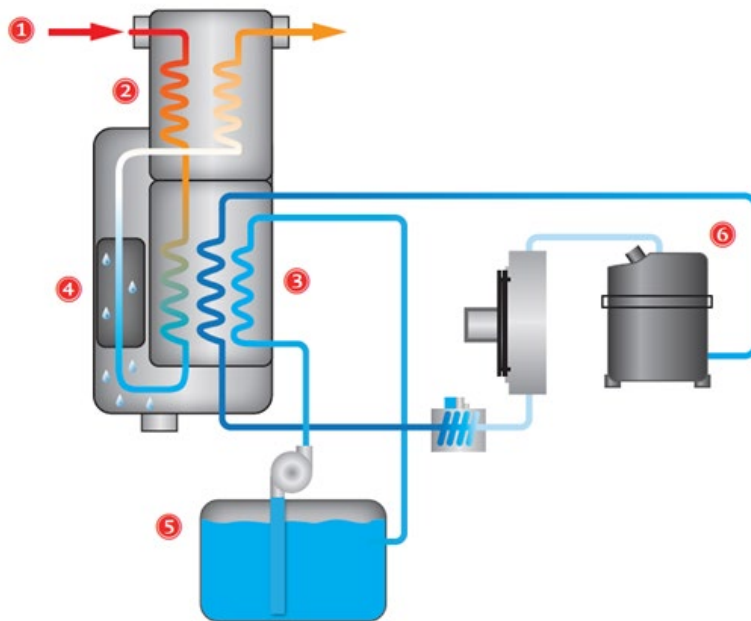

- 1 Inlet of hot compressed air from the compressor
- 2 Pre-cooling in count-flow direction to air outlet
- 3 Cooling of compressed air to the required dewpoint
- 4 Condensate separation and discharge from the compressed air pipework
- 5 Glycol circuit with submission tank for dynamic storage of cooling energy and cooling of compressed air in partial flow conditions
- 6 Refrigerant compressor (stand-by at partial flow)

Product data sheet

Refrigerant Dryer DFLO...ES

Control DFLO-ES 5.4 to DFLO-ES 100

- Indication of dryer performance and different operating modes by the display and status LED's
- Adjustable setpoint for dewpoint alert
- Indication of alarm and service messages
- Potential-free switching output (adjustable NC/ NO)

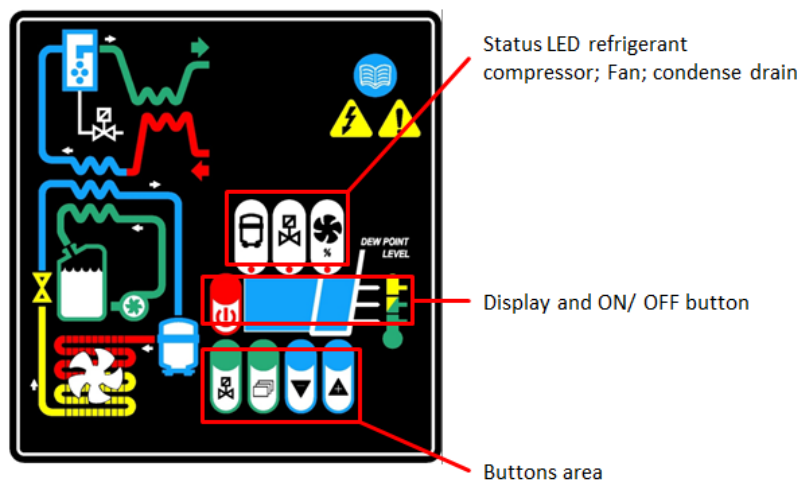

Control DFLO-ES 150 (W) to DFLO-ES 600 (W)

- Electronic microprocessor controller
- Indication of dewpoint and ambient temperature
- Adjustable alarm setpoint for dewpoint
- Indication of alarm and service messages
- Potential-free switching output (adjustable NC/ NO)

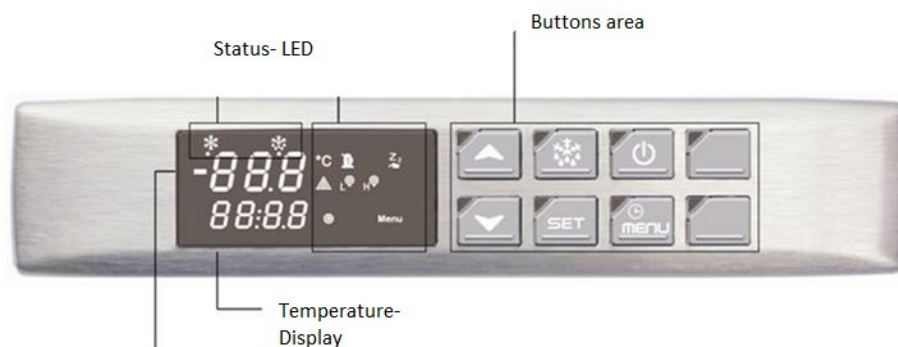

Product data sheet

Refrigerant Dryer DFLO...ES



Technical alterations reserved

Stand 21.02.2022

For latest version www.fstweb.de

Basic data

Model	Nominaler volume flow (VN) ^{*1}	Min./ Max. allowable operating pressure	Min./Max. allowable Operating temperature		recommended filter size pre-/ afterfilter (rel. tot the connection/ VN)
			Compressed air	ambient	
DFLO-ES 5.4	54 m ³ /h	2 - 16 bar	+2°C - +55°C	+2°C - +45°C	FCA 50
DFLO-ES 7.2	72 m ³ /h	2 - 16 bar			FCA 50
DFLO-ES 10.8	108 m ³ /h	2 - 16 bar			FCA 90
DFLO-ES 14.4	144 m ³ /h	2 - 16 bar			FCA 90
DFLO-ES 18	180 m ³ /h	2 - 16 bar			FCA 95
DFLO-ES 24	240 m ³ /h	2 - 16 bar			FCA 110
DFLO-ES 30	300 m ³ /h	2 - 16 bar			FCA 115
DFLO-ES 36	360 m ³ /h	2 - 16 bar			FCA 120
DFLO-ES 48	180 m ³ /h	2 - 16 bar			FCA 120
DFLO-ES 66	660 m ³ /h	2 - 16 bar			FCA 140
DFLO-ES 78	780 m ³ /h	2 - 13 bar ²			FCA 140
DFLO-ES 100	1000 m ³ /h	2 - 13 bar ²	FCA 140		
DFLO-ES 150 (W)	1.500 m ³ /h	2 - 14 bar	+2°C - +60°C	+2°C - +46°C	FCA 185
DFLO-ES 180 (W)	1.800 m ³ /h	2 - 14 bar			FCA 185
DFLO-ES 225 (W)	2.250 m ³ /h	2 - 14 bar			FCA 190
DFLO-ES 260 (W)	2.600 m ³ /h	2 - 14 bar			FCA 190
DFLO-ES 360 (W)	3.600 m ³ /h	2 - 13 bar ²			FWS 300
DFLO-ES 420 (W)	4.200 m ³ /h	2 - 13 bar ²			FWS 300
DFLO-ES 530 (W)	5.300 m ³ /h	2 - 13 bar ²			FWS 400
DFLO-ES 600 (W)	6.000 m ³ /h	2 - 13 bar ²			FWS 400

*1 - referred to 1 bar(a) and 20°C at 7 bar operating pressure, inlet temperature 35°C, cooling air 25°C and pressure dew point at outlet +3°C

*2 - optional with 16 bar operating pressure max on request

Purity classes according to ISO 8573-1

contamination	
Solid particles ^{*3}	Class 4
Water content ^{*3}	Class 4 ^{*4}
Total oil content ^{*3 *5}	Class 4

*3 - typical result, on the assumption that the suitable inlet concentrations and operating and marginal conditions are given

*4 - depending on the design (see conversion factors below)

*5 - the oil vapour content is not taken into account, it may reduce the purity class

Product data sheet

Refrigerant Dryer DFLO...ES



Technical alterations reserved

Stand 21.02.2022

For latest version www.fstweb.de

Volume flow conversion factors

«F1» - Pressure in bar (g)

5	6	7	8	9	10	11	12	13	14	15	16
0,85	0,93	1.00	1.06	1.11	1.15	1.18	1.20	1.22	1.24	1,25	1,26

«F2» - Inlet temperature in °C

30	35	40	45	50	55
1.20	1.00	0.85	0.71	0.58	0.49

«F3» - Ambient temperature / Cooling air temperature in °C

20	25	30	35	40	42	46
1.06	1.00	0.96	0.92	0,88	0.85	0.78

Calculation of the converted volume flow

Converted volume flow VK	Nominal required volume flow VN_{min}
$VK = VN \times F1 \times F2 \times F3$	$VN_{min} = VK / F1 / F2 / F3$

VK : Converted volume flow calculated for the operating conditions

VN_{min} : Nominal required volume flow calculated for the operating conditions, based on the volume flow at operating conditions

Maintenance rules

	Maintenance interval and maintenance activities
All sizes	<ul style="list-style-type: none"> ■ Daily <ul style="list-style-type: none"> - Check dewpoint, Check function of the condensate drain, by pressing drain button ■ Monthly <ul style="list-style-type: none"> - Clean condensate drain (interval could be different in dependence on compressed air quality) Remove, clean and re-insert the filter of the condensate drain group If the filter is permanently blocked, removal and cleaning of the solenoid valve may be necessary ■ Every 6 months <ul style="list-style-type: none"> - Clean refrigerant condenser (cooler fins and fan at air cooled version) using a mild detergent for cleaning (interval could be different in dependence on ambient air quality) - Water-cooled models: Check initial pressure of cooling water ■ Yearly <ul style="list-style-type: none"> - Leak tightness check : *5 for refrigerant dryers with filling <30 kg refrigerant the maximum allowed leak rate of 2% must not be exceeded ■ Periodical checks <ul style="list-style-type: none"> The user of the dryer has to find out the test periods of the complete installation and the unit parts on base of a safety related technical evaluation. In Germany BetrSichV of September 27th, 2002 (BGBl. I S.3777) §15

*5 –Maintenance and works on refrigerant circuits has to be provided by qualified personnel only (see. EN 13313)

For the qualified personnel a yearly instruction (acc. BetrSichV §9I, EN378-1, BGR 500 2.35) is mandatory

Product data sheet

Refrigerant Dryer DFLO...ES



Technical alterations reserved

Stand 21.02.2022

For latest version www.fstweb.de

Product specific mechanical data

Model	Pressure drop	Cool.air Air-cooled *6	Chill water water-cooled	refrigerant	Qty. Of refrigerant*7 air-cooled /water-cooled	CO ₂ equivalent	Noise level Air-cooled /water-cooled
DFLO-ES 5.4	0,09 bar	300 m ³ /h	---	R513a	0,25 kg	0,4 t	70 dB(A)
DFLO-ES 7.2	0,16 bar	250 m ³ /h	---	R513a	0,28 kg	0,4 t	70 dB(A)
DFLO-ES 10.8	0,09 bar	370 m ³ /h	---	R513a	0,30 kg	0,4 t	70 dB(A)
DFLO-ES 14.4	0,18 bar	570 m ³ /h	---	R513a	0,30 kg	0,4 t	70 dB(A)
DFLO-ES 18	0,12 bar	690 m ³ /h	---	R513a	0,40 kg	0,6 t	70 dB(A)
DFLO-ES 24	0,20 bar	750 m ³ /h	---	R407C	0,55 kg	1,0 t	70 dB(A)
DFLO-ES 30	0,16 bar	850 m ³ /h	---	R407C	0,80 kg	1,4 t	70 dB(A)
DFLO-ES 36	0,21 bar	2700 m ³ /h	---	R407C	0,80 kg	1,4 t	70 dB(A)
DFLO-ES 48	0,18 bar	2300 m ³ /h	---	R407C	1,20 kg	2,1 t	70 dB(A)
DFLO-ES 66	0,17 bar	2500 m ³ /h	---	R407C	1,7 kg	2,9 t	70 dB(A)
DFLO-ES 78	0,18 bar	2800 m ³ /h	---	R407C	2,25 kg	4,0 t	70 dB(A)
DFLO-ES 100	0,24 bar	2800 m ³ /h	---	R407C	2,25 kg	4,0 t	70 dB(A)
DFLO-ES 150 (W)	0,16 bar	8.500 m ³ /h	2,1 m ³ /h	R407C	4,4 kg / 3,5 kg	6,2 t	78 dB(A) / 70 dB(A)
DFLO-ES 180 (W)	0,23 bar	8.500 m ³ /h	2,1 m ³ /h	R407C	4,4 kg / 3,5 kg	6,2 t	78 dB(A) / 70 dB(A)
DFLO-ES 225 (W)	0,25 bar	6.800 m ³ /h	3,6 m ³ /h	R407C	5,2 kg / 4,2 kg	6,9 t	78 dB(A) / 70 dB(A)
DFLO-ES 260 (W)	0,26 bar	6.800 m ³ /h	3,8 m ³ /h	R407C	6,0 kg / 5,0 kg	10,6 t	78 dB(A) / 70 dB(A)
DFLO-ES 360 (W)	0,25 bar	17.000 m ³ /h	4,9 m ³ /h	R407C	9,0 kg / 8,0 kg	14,2 t	78 dB(A) / 70 dB(A)
DFLO-ES 420 (W)	0,29 bar	13.600 m ³ /h	5,5 m ³ /h	R407C	9,0 kg / 8,0 kg	15,3 t	78 dB(A) / 70 dB(A)
DFLO-ES 530 (W)	0,25 bar	13.600 m ³ /h	7,6 m ³ /h	R407C	11,8 kg / 11,0 kg	19,5 t	78 dB(A) / 70 dB(A)
DFLO-ES 600 (W)	0,28 bar	13.600 m ³ /h	7,6 m ³ /h	R407C	11,8 kg / 11,0 kg	19,5 t	78 dB(A) / 70 dB(A)

*6 – cooling water inlet pressure min 2 bar (g), max. 10 bar (g), cooling water inlet temperature 30°C
cooling water pressostatic valve for use of cooling water temperature < 30°C is standard scope of supply

*7 – The user is committed to keep records of the refrigerant unit if the refrigerant filling is > 3kg (DIN EN378-4.3.1, EG-regulation 842/2006)

Product data sheet

Refrigerant Dryer DFLO...ES

Product specific electrical data

Model	Electr. connection	Installed power* ⁸	Power consumption* ^{8,9}	Max. current* ⁸	Reommended fuse* ⁹	Protection class
DFLO-ES 5.4	230V / 50Hz / 1Ph	0,24	0,2 kW	1,5 A	10 A	IP 42
DFLO-ES 7.2		0,44	0,3 kW	1,9 A	10 A	
DFLO-ES 10.8		0,67	0,45	2,7 A	10 A	
DFLO-ES 14.4		0,78	0,51	3,1 A	10 A	
DFLO-ES 18		0,72	0,54	3,5 A	10 A	
DFLO-ES 24		0,88	0,64	2,9 A	10 A	
DFLO-ES 30		1,32	0,79	4,0 A	10 A	
DFLO-ES 36		1,32	0,94	4,8 A	10 A	
DFLO-ES 48		1,77	1,03	4,9 A	10 A	
DFLO-ES 66		1,8 kW	1,3 kW	8,7 A	10 A	
DFLO-ES 78		400V (± 10%) 50Hz / 3Ph 460V (± 10%) 60Hz / 3Ph On request	3,5 kW	1,9 kW	5,9 A	
DFLO-ES 100	3,5 kW		1,9 kW	5,9 A	10 A	
DFLO-ES 150 (W)	4,9 kW		2,5 kW	9,5 A	16 A	
DFLO-ES 180 (W)	4,9 kW		2,5 kW	9,5 A	10 A	
DFLO-ES 225 (W)	5,4 kW		3,7 kW	9,3 A	10 A	
DFLO-ES 260 (W)	6,4 kW		4,67 kW	12,3 A	16 A	
DFLO-ES 360 (W)	12,2 kW		8,0 kW	16,0 A	50 A	
DFLO-ES 420 (W)	12,2 kW		8,0 kW	16,0 A	50 A	
DFLO-ES 530 (W)	16,0 kW		10,3 kW	26,3 A	50 A	
DFLO-ES 600 (W)	16,0 kW		10,3 kW	26,3 A	50 A	

*⁸ – for 400 V / 50 Hz systems (data for 460 V / 60 Hz on request)

*⁹ – at full load (nom. volume flow rate at 20°C/1 bar(a) at 7 bar(g), medium 35°C, cooling air 25°C, pressure dew point +3°C)

Product data sheet

Refrigerant Dryer DFLO...ES



Technical alterations reserved

Stand 21.02.2022

For latest version www.fstweb.de

Connections, dimensions and weight

Model	Connect.	Height	Width	Depth	Connect. Cool. water	weight air-cooled / water-cooled
DFLO-ES 5.4	½"	651 mm	386 mm	500 mm	---	33 kg
DFLO-ES 7.2	½"	651 mm	386 mm	500 mm	---	35 kg
DFLO-ES 10.8	¾"	651 mm	386 mm	500 mm	---	45 kg
DFLO-ES 14.4	¾"	651 mm	386 mm	500 mm	---	50 kg
DFLO-ES 18	1"	771 mm	420 mm	567 mm	---	60 kg
DFLO-ES 24	1"	771 mm	420 mm	567 mm	---	70 kg
DFLO-ES 30	1½"	980 mm	500 mm	720 mm	---	95 kg
DFLO-ES 36	1½"	980 mm	500 mm	720 mm	---	100 kg
DFLO-ES 48	1½"	980 mm	500 mm	720 mm	---	130 kg
DFLO-ES 66	G 2"	1340 mm	750 mm	780 mm	---	186 kg
DFLO-ES 78	G 2"	1340 mm	750 mm	780 mm	---	227 kg
DFLO-ES 100	G 2"	1340 mm	750 mm	780 mm	---	237 kg
DFLO-ES 150 (W)	G 3"	1539 mm	806 mm	1012 mm	3/4"	244 kg / 270 kg
DFLO 180-ES (W)	G 3"	1539 mm	806 mm	1012 mm	3/4"	244 kg / 270 kg
DFLO 225-ES (W)	G 3"	1539 mm	806 mm	1012 mm	1 ½"	270 kg / 300 kg
DFLO 260-ES (W)	G 3"	1539 mm	806 mm	1012 mm	1 ½"	399 kg / 410 kg
DFLO 360-ES (W)	DN 125	1570 mm	1510 mm	1500 mm	1 ½"	420 kg / 420 kg
DFLO 420-ES (W)	DN 125	1570 mm	1510 mm	1500 mm	1 ½"	520 kg / 520 kg
DFLO 530-ES (W)	DN 150	1570 mm	1510 mm	1500 mm	1 ½"	620 kg / 620 kg
DFLO 600-ES (W)	DN 150	1570 mm	1510 mm	1500 mm	1 ½"	720 kg / 720 kg

Product data sheet

Refrigerant Dryer DFLO...ES



Technical alterations reserved

Stand 21.02.2022

For latest version www.fstweb.de

Classification according to Pressure Equipment Directive 2014/68/EU for group 2 fluids

Model	Volume	Category
DFLO-ES 5.4	1,03 l	Art. 3.3
DFLO-ES 7.2	1,03 l	Art. 3.3
DFLO-ES 10.8	3,00 l	Art. 3.3
DFLO-ES 14.4	3,00 l	Art. 3.3
DFLO-ES 18	4,82 l	I
DFLO-ES 24	4,82 l	I
DFLO-ES 30	6,95 l	I
DFLO-ES 36	6,95 l	I
DFLO-ES 48	11,6 l	I
DFLO-ES 66	12,4 l	I
DFLO-ES 78	12,4 l	I
DFLO-ES 100	15,3 l	II
DFLO-ES 150 (W)	1 x 32,9 l	II
DFLO-ES 180 (W)	1 x 32,9 l	II
DFLO-ES 225 (W)	1 x 41,7 l	II
DFLO-ES 260 (W)	1 x 41,7 l	II
DFLO-ES 360 (W)	4 x 12,4 l	II
DFLO-ES 420 (W)	4 x 15,3 l	II
DFLO-ES 530 (W)	6 x 15,3 l	II
DFLO-ES 600 (W)	6 x 15,3 l	II

Other directives

This machinery was designed and built in accordance with the European safety regulations.		Size
2006/42/CE	EG- machinery directive	All sizes
2006/95/CE	EEC low voltage directive	
2004/108/CE	Electromagnetic compability device of the European Energy Unity	
97/23/CE	EG- pressure directive (PED)	

Product data sheet

Refrigerant Dryer DFLO...ES

Technical alterations reserved

Stand 21.02.2022

For latest version www.fstweb.de

Dimension sheets DFLO-ES 5.4-48

DFLO-ES 5.4-14.4

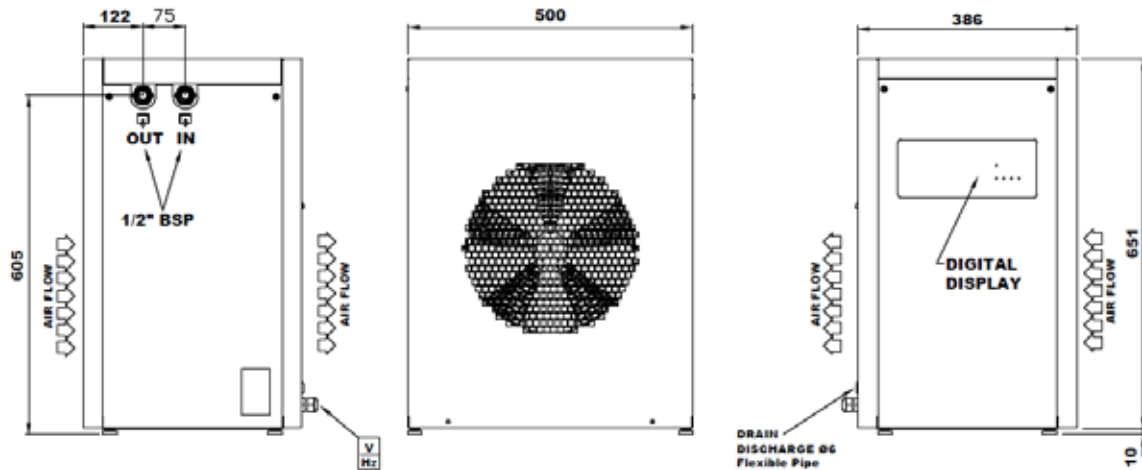

DFLO-ES 18-24

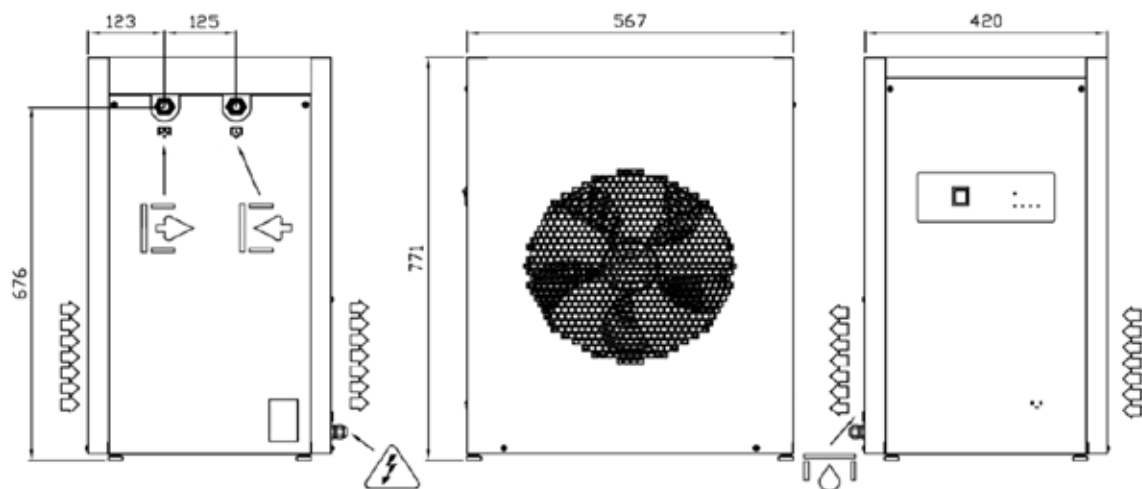

DFLO-ES 30-48

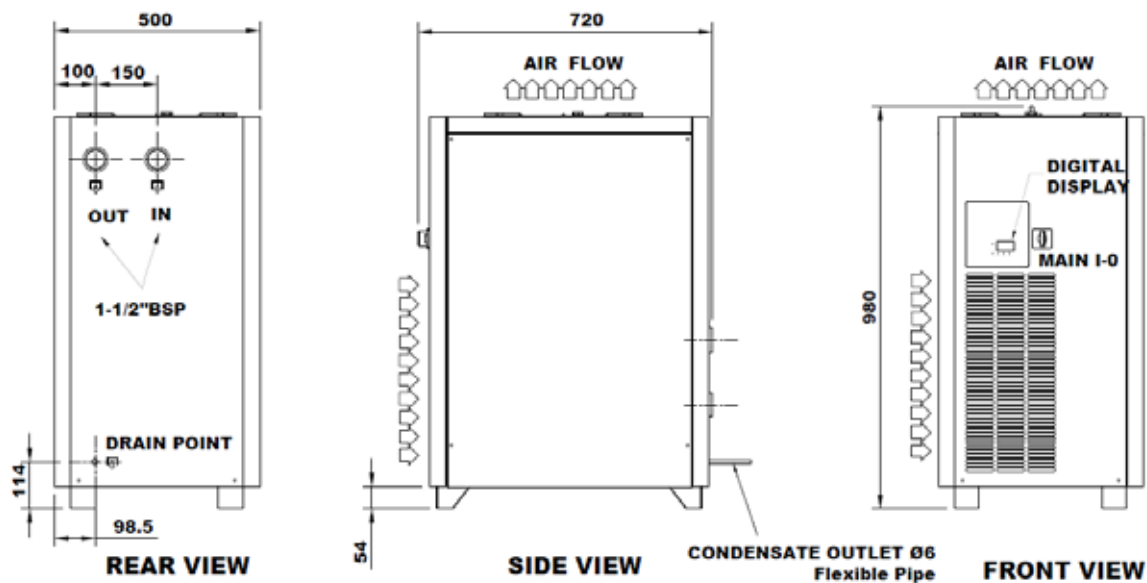

Product data sheet

Refrigerant Dryer DFLO...ES

Technical alterations reserved

Stand 21.02.2022

For latest version www.fstweb.de

Dimension sheets DFLO-ES 66-260

DFLO-ES 66-100

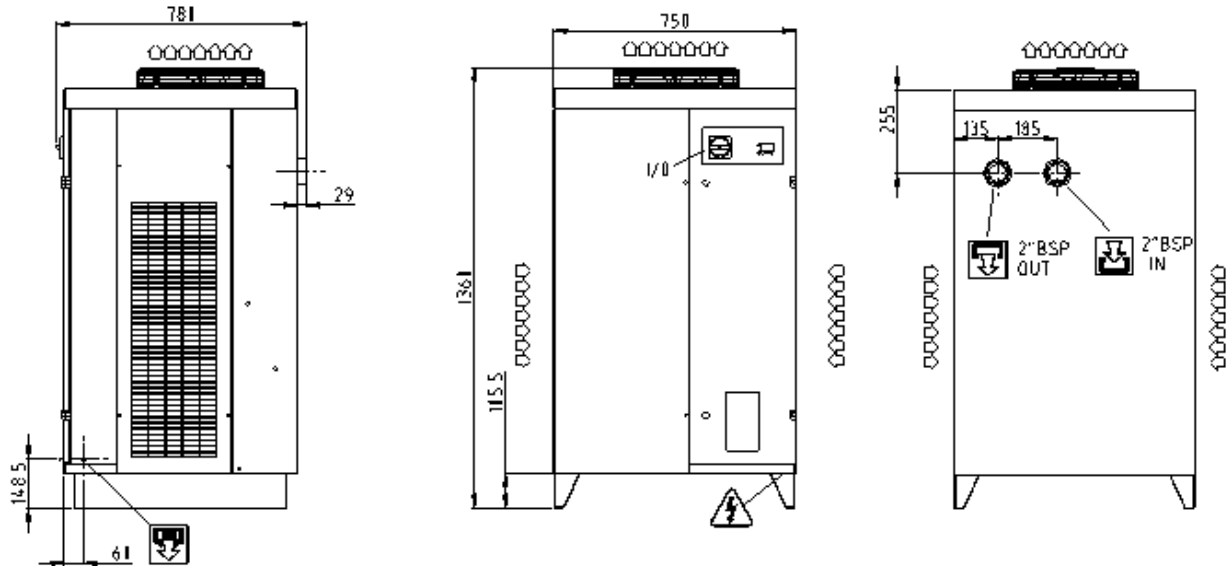

DFLO-ES 150-225

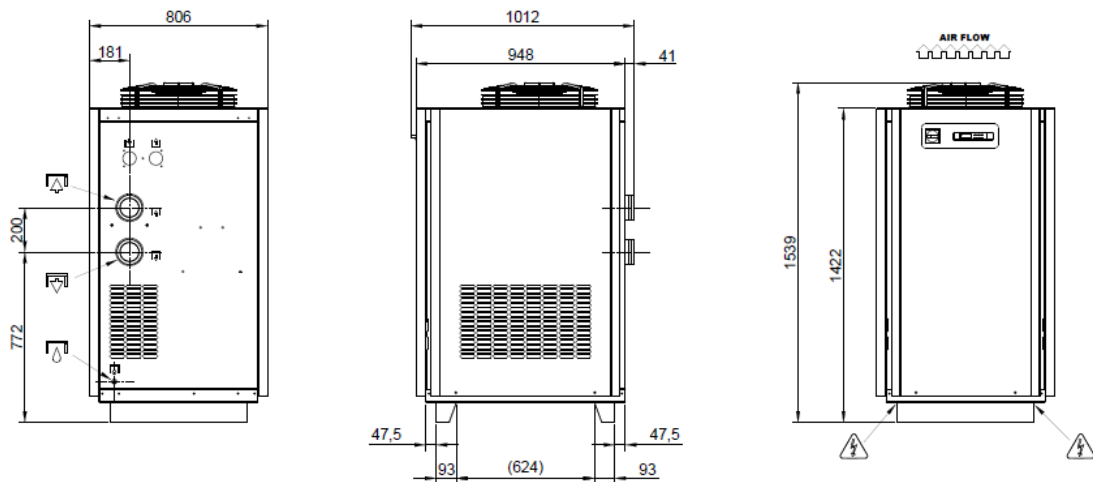

DFLO-ES 270

Product data sheet

Refrigerant Dryer DFLO...ES

Technical alterations reserved

Stand 21.02.2022

For latest version www.fstweb.de

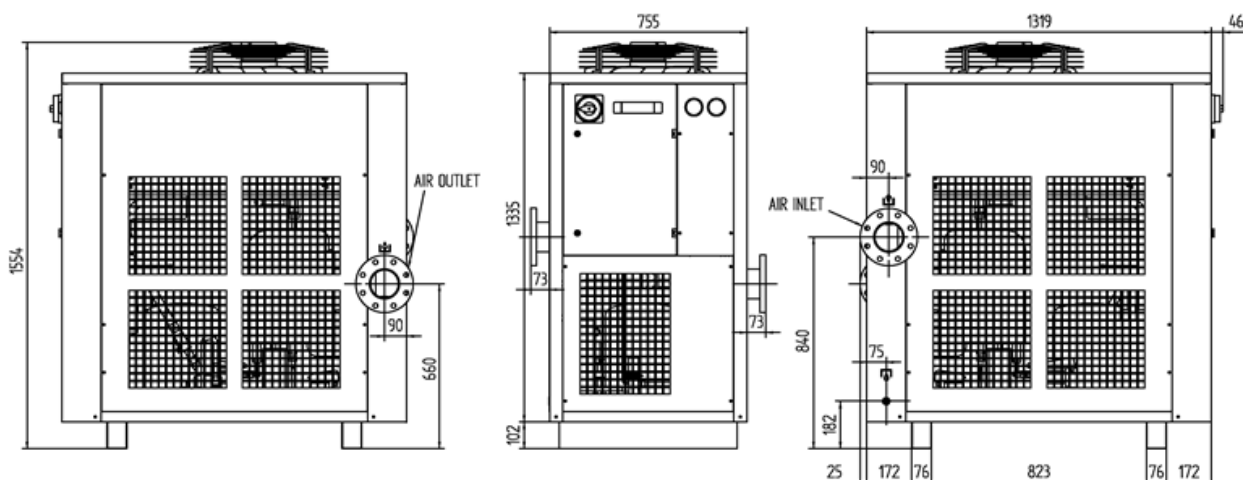

Dimension sheets DFLO-ES 360-600

DFLO-ES 360-600

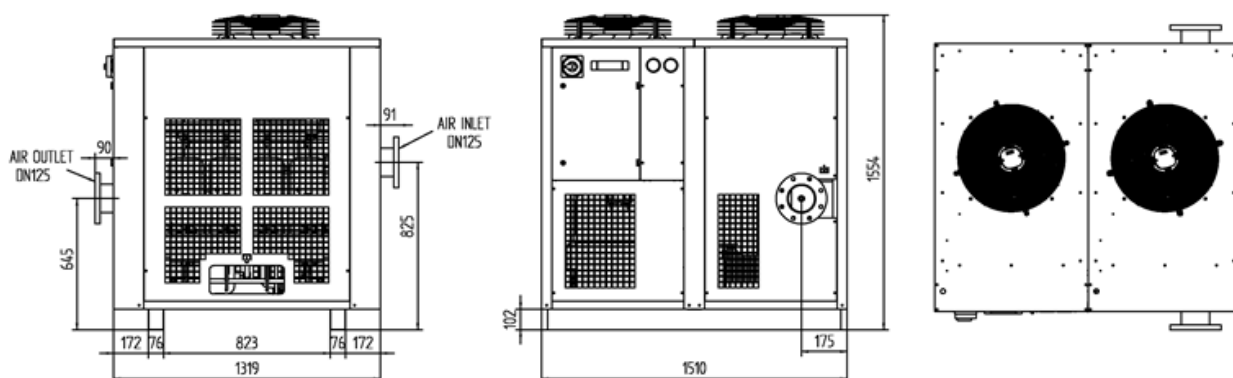

Model	DFLO-ES 66	DFLO-ES 78	DFLO-ES 100	DFLO-ES 150	DFLO-ES 180	DFLO-ES 225	DFLO-ES 270	DFLO-ES 360	DFLO-ES 420	DFLO-ES 530	DFLO-ES 600	
Number of evaporators	1		2			3	4		6			
Number of Condensators	1						2					
Number of Condensate drains	1			2								

Product data sheet

Refrigerant Dryer DFLO...ES

Technical alterations reserved

Stand 21.02.2022

For latest version www.fstweb.de

Flow diagramm (PID) DFLO-ES 150-225

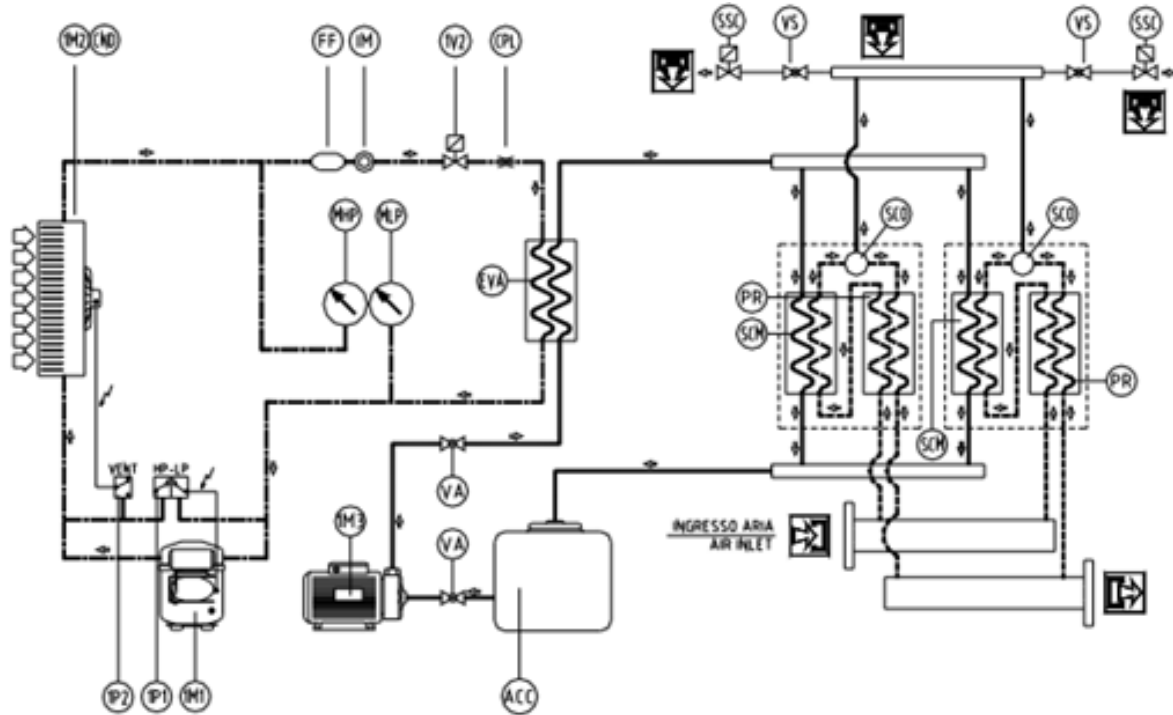

Flow diagramm (PID) DFLO-ES 260

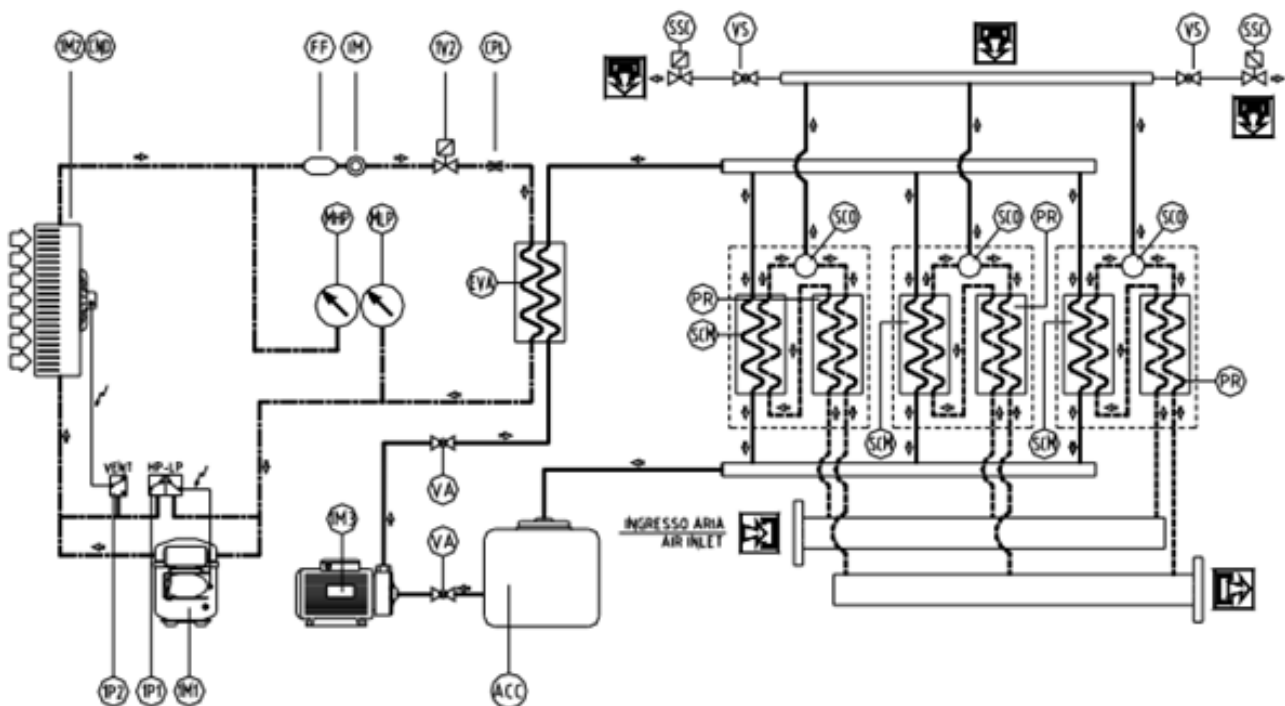

Product data sheet

Refrigerant Dryer DFLO...ES

Technical alterations reserved

Stand 21.02.2022

For latest version www.fstweb.de

Flow diagramm (PID) DFLO-ES 360-420

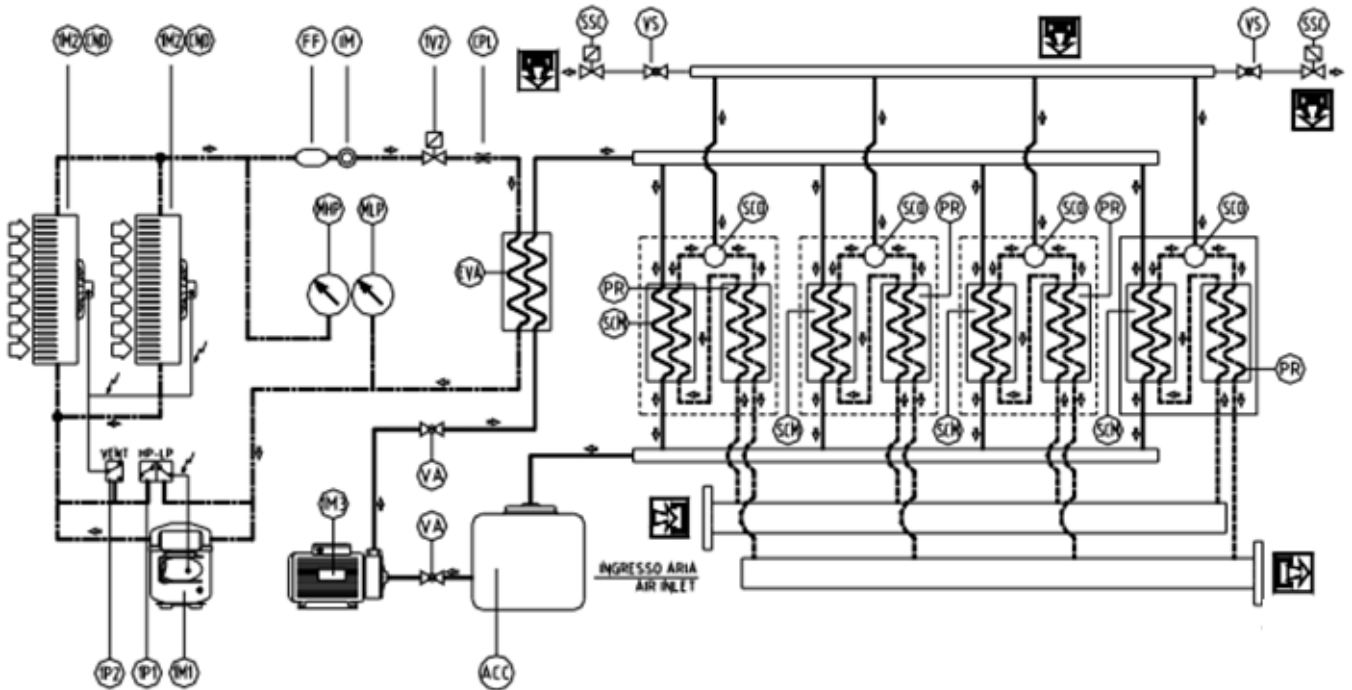

Flow diagramm (PID) DFLO-ES 530-600

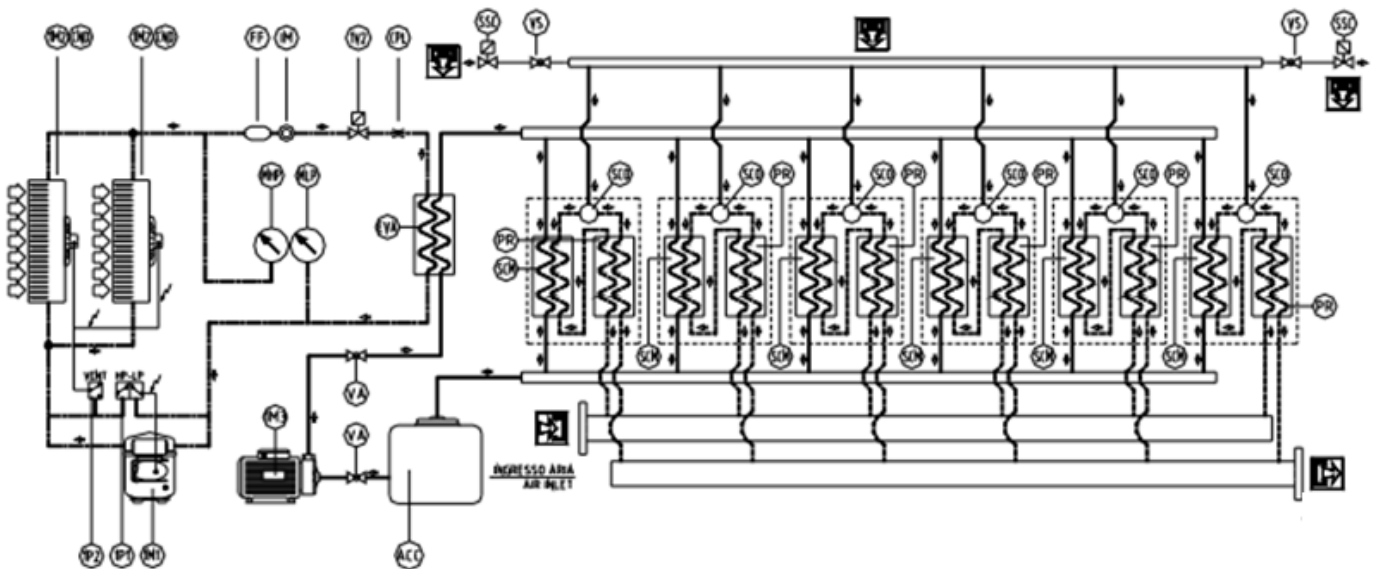

Product data sheet

Refrigerant Dryer DFLO...ES

Technical alterations reserved

Stand 21.02.2022

For latest version www.fstweb.de

Legend to Flow diagramm (PID)

1M1	Hermetic refrigerant compressor
1M2	Fan motor
1M3	Glykol pump
1P1	High pressure Switch (from DFLO-ES 78)
1P2	Fan pressure Switch (not for watercooled version)
1V1	Condensate drain
ACC	Glykol tank
CND	Condenser Refrigerant/ air heat exchanger (at watercooled version Refrigerant /Water heat exchanger)
CPL	Capillary tube
EVA	Evaporator valve
FF	Filter dryer
IM	Sight glass
MHP	Refrigerant High pressure Manometer
MLP	Refrigerant Low pressure Manometer
PR	Air/ air heat exchanger
RBF	Ball valve with strainer
SCO	Condensate separator
VA	Shut-off valve Glykol

Product data sheet

Refrigerant Dryer DFLO...ES



Technical alterations reserved

Stand 21.02.2022

For latest version www.fstweb.de

Notes

Product data sheet

Refrigerant Dryer DFLO...ES

Technical alterations reserved

Stand 21.02.2022

For latest version www.fstweb.de

Accessories



The DA-CM1-230 switch-over control system enables the control of two redundant compressed air dryers in a compressed air system. The two dryers can be operated alternately while switching-over automatically. All dryers, provided with a «remote start/stop contact» or a «compressor synchronisation contact», can be directly connected to the switch-over control system without the need for any further modifications. The DA-CM1-230 also controls all required shut-off valves (no scope of supply) to open or close the compressed air line to a dryer (e.g. solenoid valves or valves with actuating drive for 230V AC supply voltage). Furthermore, additional input signals can be hooked up to the common alarm message of each dryer. Beside the power supply the DA-CM1-230 provides alarm inputs for condensate drains, differential pressure gauges, etc. for each dryer.

The GSM Module DA-ETR-107 is an easy to install extension for all dryers with alarm contact. In case of an alarm a SMS message is send to up to 6 different recipients or, if supported by the provider, an email message. Within the message, the dryer type and serial number is transferred, if required.

The programming can be done with a usual mobile phone, protected by the PIN code of the SIM card (no scope of supply) applied to the GSM module. The DA-ETR-107 is operated with 5-32V DC supply voltage. An internal battery ensures operation of up to 120 hours in case of loss of the supply voltage. The GSM module has an integrated antenna while an external antenna can be connected in the case of low signal levels.



The Start-up device (minimum pressure valve) DA-VPM-... protects the dryer from overload due to high flow velocities during pressure build-up of the compressed air system. For connection size G ½ to G 2½ spring loaded angle valves are offered (DA-VPM-B../16), providing an opening pressure of 3-5 bar (standard 3.5 bar). For connection size DN80 to DN250 butterfly valves with pneumatic actuator are offered (DA-VPM-F../11), directly operated by the working pressure while opening at 3 bar (full cross-section at 4 bar). Special versions with adjustable opening pressure or working pressures of up to 450 bar are available on request.



Differential pressure gauges FAD01C with potential free alarm contact allow to hook up the differential pressure control of the pre- and after-filter to the common alarm message of each dryer. In order to avoid a false error report due to start-up conditions or short-time peaks, an alarm delay can be set in the dryer control unit. The alarm message then will just be generated, if a too high differential pressure was indicated during the entire delay time interval.

... and many more. Please contact us.