

Product Data Sheet Refrigeration Dryer

DFLO 2.4 to DFLO 2400 (-W)

Version: 1.9.2.

Author: Karsten Unger

Date: 09.02.2023

Field of application

Refrigeration dryers of the DFLO series are designed for drying compressed air flows to pressure dew points up to +3°C for compressed air without aggressive substances.



Function

Refrigeration dryers of the DFLO series mainly consist of two heat exchangers and a controlled refrigerant circuit. In the first heat exchanger, the air/air heat exchanger, the incoming compressed air flow will be pre-cooled by the outgoing compressed air flow in the counterflow circuit, which is already cooled down to the dewpoint temperature. This means that additional energy for pre-cooling is not required. In the second heat exchanger, the refrigerant/air heat exchanger, which is cooled by the refrigerant circuit, the compressed air is cooled down to the minimum temperature (dewpoint temperature). During the entire cooling process moisture in the compressed air precipitates in the form of condensate which is collected centrally and discharged automatically. Finally, the compressed air is heated and thus subsaturated in the air/air heat exchanger by the warm incoming compressed air in the counterflow circuit. As long as the compressed air temperature does not fall below the pressure dew point, condensate will no longer be generated. To prevent the dryer from freezing when being operated at partial load, the cooling capacity generated by the refrigerant circuit has to be controlled. For the DFLO series a hot gas bypass controller is used for controlling. The heat generated during the process is discharged to the environment using axial fans. The amount of heated air must be taken into account when venting the place of installation. All models are available as water cooled version [(-W)], and already contain a cooling water regulating valve.

Product Data Sheet

Refrigeration Dryer DFLO...

Features

All the models are provided with an electronic condensate drain and a potential free alarm contact as standard. The refrigeration dryers comply with the requirements of the Pressure Equipment Directive 2014/68/EU as well as with the Machinery Directive 2006/42/EC and have the corresponding CE marking.

The air-to-air heat exchanger, the evaporator and the demister condensate separator made from aluminium are comprised in one module. This results in a compact, rugged and energy-saving design. The cooling registers are designed such that the condensate is discharged on the entire cooling path (in conventional refrigeration dryers the condensate is only discharged at the end of the cooling circuit). The generously designed air circuit causes low flow velocities and therefore results in very good condensate separation and very low pressure losses.

Controller DFLO 2.4 - DFLO 100 (W)

- Display for efficiency and various working conditions
- adjustable dewpoint alarm value
- indication of alarm- and service messages
- potential free group error contact (programmable NC/ NO)

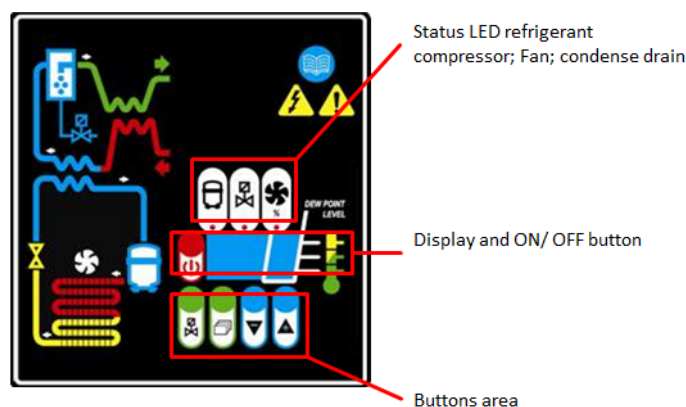

Controller DFLO 150 (W) - DFLO 24000 (W)

- electronic microprocessor controller
- Display dewpoint and ambient temperature
- Adjustable setpoint for dewpoint alert
- Display alarm and service information
- Potentialfree switching output (programmable NC/ NO)

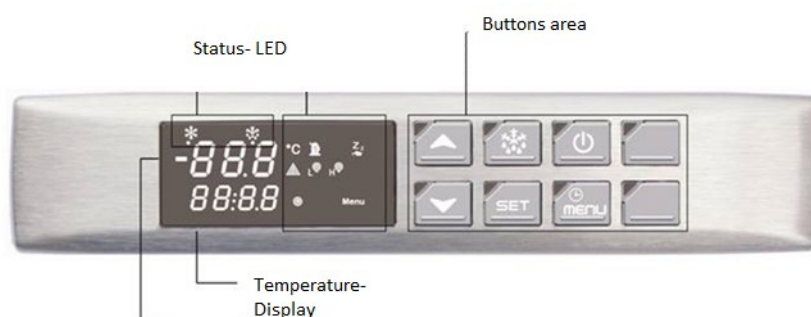

Product Data Sheet

Refrigeration Dryer DFLO...



Specifications subject to change without notice

Date 09.02.2023

Latest version see www.fstweb.de

Basic data

Model	Nominal volume flow (VN) ^{*1}	Min./ Max. allowable operating pressure	Min./Max. allowable operating pressure	
			compressed air	ambient air
DFLO 2.4	24 m ³ /h	2 - 16 bar	+2°C - +55°C	+2°C - +45°C
DFLO 5.4	54 m ³ /h	2 - 16 bar		
DFLO 7.2	72 m ³ /h	2 - 16 bar		
DFLO 10.8	108 m ³ /h	2 - 16 bar		
DFLO 14.4	144 m ³ /h	2 - 16 bar		
DFLO 18	180 m ³ /h	2 - 16 bar		
DFLO 22.5	224 m ³ /h	2 - 16 bar		
DFLO 26	260 m ³ /h	2 - 16 bar		
DFLO 36	360 m ³ /h	2 - 16 bar		
DFLO 48	480 m ³ /h	2 - 16 bar		
DFLO 66 (W)	660 m ³ /h	2 - 16 bar		
DFLO 78 (W)	780 m ³ /h	2 - 16 bar		
DFLO 100 (W)	1000 m ³ /h	2 – 13 bar ⁽²⁾		
DFLO 150 (W)	1.500 m ³ /h	2 - 14 bar		
DFLO 180 (W)	1.800 m ³ /h	2 - 14 bar		
DFLO 225 (W)	2.250 m ³ /h	2 - 14 bar		
DFLO 270 (W)	2.700 m ³ /h	2 – 13 bar ⁽²⁾		
DFLO 360 (W)	3.600 m ³ /h	2 – 13 bar ⁽²⁾		
DFLO 420 (W)	4.200 m ³ /h	2 – 13 bar ⁽²⁾		
DFLO 530 (W)	5.300 m ³ /h	2 – 13 bar ⁽²⁾		
DFLO 600 (W)	6.000 m ³ /h	2 – 13 bar ⁽²⁾		
DFLO 680 (W)	6.800 m ³ /h	2 – 13 bar ⁽²⁾		
DFLO 880 (W)	8.800 m ³ /h	2 – 13 bar ⁽²⁾		
DFLO 1000 (W)	10.000 m ³ /h	2 – 13 bar ⁽²⁾		
DFLO 1200 (W)	12.000 m ³ /h	2 – 13 bar ⁽²⁾		
DFLO 1360 (W)	13.600 m ³ /h	2 – 13 bar ⁽²⁾		
DFLO 1760 (W)	17.600 m ³ /h	2 – 13 bar ⁽²⁾		
DFLO 2000 (W)	20.000 m ³ /h	2 – 13 bar ⁽²⁾		
DFLO 2400 (W)	24.000 m ³ /h	2 – 13 bar ⁽²⁾		

*1 - referred to 1 bar(a) and 20°C at 7 bar operating pressure, inlet temperature 35°C, cooling air 25°C and pressure dew point at outlet +3°C

*2 - optional max. working pressure 16 bar on request

Purity classes according to ISO 8573-1

contamination	
Solid particles ^{*2}	Class 4
Water content ^{*2}	Class 4 ^{*3}
Total oil content ^{*2 *4}	Class 4

*2 - typical result, on the assumption that the suitable inlet concentrations and operating and marginal conditions are given

*3 - depending on the design (see conversion factors below)

*4 - the oil vapour content is not taken into account, it may reduce the purity class

Product Data Sheet

Refrigeration Dryer DFLO...



Specifications subject to change without notice

Date 09.02.2023

Latest version see www.fstweb.de

Volume flow conversion factors

«F1» - Pressure in bar (g)

5	6	7	8	9	10	11	12	13	14	15	16
0,85	0,93	1.00	1.06	1.11	1.15	1.18	1.20	1.22	1.24	1,25	1,26

«F2» - Inlet temperature in °C

30	35	40	45	50	55
1.20	1.00	0.85	0.71	0.58	0.49

«F3» - Ambient temperature / Cooling air temperature in °C

20	25	30	35	40	42	45
1.06	1.00	0.96	0.92	0,88	0.85	0.8

Calculation of the converted volume flow

Converted volume flow VK	Nominal required volume flow VN_{min}
$VK = VN \times F1 \times F2 \times F3$	$VN_{min} = VK / F1 / F2 / F3$

VK : Converted volume flow calculated for the operating conditions

VN_{min} : Nominal required volume flow calculated for the operating conditions, based on the volume flow at operating conditions

Maintenance rules

	Maintenance interval and maintenance activities
All sizes	<ul style="list-style-type: none"> ■ Daily <ul style="list-style-type: none"> - Check dewpoint, Check function of the condensate drain, by pressing drain button ■ Monthly <ul style="list-style-type: none"> - Clean condensate drain (interval could be different in dependence on compressed air quality) Remove, clean and re-insert the filter of the condensate drain group If the filter is permanently blocked, removal and cleaning of the solenoid valve may be necessary - Clean refrigerant condenser (cooler fins and fan at air cooled version) using a mild detergent for cleaning (interval could be different in dependence on ambient air quality) - Water-cooled models: Check initial pressure of cooling water ■ Yearly <ul style="list-style-type: none"> - Leak tightness check : *5 for refrigerant dryers with filling <30 kg refrigerant the maximum allowed leak rate of 2% must not be exceeded ■ Periodical checks <ul style="list-style-type: none"> The user of the dryer has to find out the test periods of the complete installation and the unit parts on base of a safety related technical evaluation. In Germany BetrSichV of September 27th, 2002 (BGBl. I S.3777) §15

*5 –Maintenance and works on refrigerant circuits has to be provided by qualified personnel only (see. EN 13313)

For the qualified personnel a yearly instruction (acc. BetrSichV §9I, EN378-1, BGR 500 2.35) is mandatory

Product Data Sheet

Refrigeration Dryer DFLO...



Specifications subject to change without notice

Date 09.02.2023

Latest version see www.fstweb.de

Product specific mechanical data

Model	Pressure drop	Cooling air requirement	Cooling water ^{*6} requirement	Refrigerant type	Amount of refrigerant ^{*7} aircooled / watercooled	Noise level aircooled / watercooled
DFLO 2.4	0,04 bar	350 m ³ /h	---	R 134a	0,17 kg / ---	70 dB(A) / 70 dB(A)
DFLO 5.4	0,07 bar	300 m ³ /h	---	R 134a	0,23 kg / ---	70 dB(A) / 70 dB(A)
DFLO 7.2	0,13 bar	250 m ³ /h	---	R 134a	0,33 kg / ---	70 dB(A) / 70 dB(A)
DFLO 10.8	0,07 bar	370 m ³ /h	---	R 134a	0,3 kg / ---	70 dB(A) / 70 dB(A)
DFLO 14.4	0,13 bar	570 m ³ /h	---	R 134a	0,32 kg / ---	70 dB(A) / 70 dB(A)
DFLO 18	0,21 bar	690 m ³ /h	---	R 134a	0,48 kg / ---	70 dB(A) / 70 dB(A)
DFLO 22.5	0,17 bar	750 m ³ /h	---	R 134a	0,51 kg / ---	70 dB(A) / 70 dB(A)
DFLO 26	0,23 bar	850 m ³ /h	---	R 407C	0,7 kg / ---	70 dB(A) / 70 dB(A)
DFLO 36	0,17 bar	2700 m ³ /h	---	R 407C	0,95 kg / ---	70 dB(A) / 70 dB(A)
DFLO 48	0,3 bar	2300 m ³ /h	---	R 407C	1,2 kg / ---	70 dB(A) / 70 dB(A)
DFLO 66 (W)	0,25 bar	2500 m ³ /h	1,1 m ³ /h	R407C	1,7 kg / 1,5 kg	70 dB(A) / 70 dB(A)
DFLO 78 (W)	0,24 bar	2800 m ³ /h	1,6 m ³ /h	R407C	2,15 kg / 1,8 kg	70 dB(A) / 70 dB(A)
DFLO 100 (W)	0,24 bar	2800 m ³ /h	1,6 m ³ /h	R407C	2,25 kg / 1,85 kg	70 dB(A) / 70 dB(A)
DFLO 150 (W)	0,16 bar	8.500 m ³ /h	2,1 m ³ /h	R407C	4,5 kg / 3,5 kg	78 dB(A) / 70 dB(A)
DFLO 180 (W)	0,23 bar	8.500 m ³ /h	2,1 m ³ /h	R407C	4,5 kg / 3,5 kg	78 dB(A) / 70 dB(A)
DFLO 225 (W)	0,25 bar	6.800 m ³ /h	3,6 m ³ /h	R407C	4,9 kg / 3,9 kg	78 dB(A) / 70 dB(A)
DFLO 270 (W)	0,30 bar	6.800 m ³ /h	3,8 m ³ /h	R407C	5,5 kg / 4,5 kg	78 dB(A) / 70 dB(A)
DFLO 360 (W)	0,30 bar	17.000 m ³ /h	4,9 m ³ /h	R407C	7,5 kg / 6,5 kg	78 dB(A) / 70 dB(A)
DFLO 420 (W)	0,30 bar	13.600 m ³ /h	5,5 m ³ /h	R407C	9,0 kg / 8,0 kg	78 dB(A) / 70 dB(A)
DFLO 530 (W)	0,30 bar	13.600 m ³ /h	7,6 m ³ /h	R407C	11,7 kg / 10,0 kg	78 dB(A) / 70 dB(A)
DFLO 600 (W)	0,28 bar	13.600 m ³ /h	7,6 m ³ /h	R407C	12,7 kg / 11,0 kg	78 dB(A) / 70 dB(A)
DFLO 680 (W)	0,28 bar	15.800 m ³ /h	8,8 m ³ /h	R407C	13,0 kg / 11,0 kg	78 dB(A) / 70 dB(A)
DFLO 880 (W)	0,28 bar	20.400 m ³ /h	11,7 m ³ /h	R407C	20,0 kg / 18,0 kg	78 dB(A) / 70 dB(A)
DFLO 1000 (W)	0,30 bar	20.400 m ³ /h	11,7 m ³ /h	R407C	21,0 kg / 20,0 kg	78 dB(A) / 70 dB(A)
DFLO 1200 (W)	0,30 bar	23.700 m ³ /h	14,3 m ³ /h	R407C	23,7 kg / 23,0 kg	78 dB(A) / 70 dB(A)
DFLO 1360 (W)	0,30 bar	31.600 m ³ /h	17,7 m ³ /h	R407C	27,0 kg / 25,0 kg	78 dB(A) / 70 dB(A)
DFLO 1760 (W)	0,30 bar	40.800 m ³ /h	23,4 m ³ /h	R407C	2x 20,0 kg / 18,0 kg	78 dB(A) / 70 dB(A)
DFLO 2000 (W)	0,28 bar	40.800 m ³ /h	23,4 m ³ /h	R407C	2x 21,0 kg / 20,0 kg	78 dB(A) / 70 dB(A)
DFLO 2400 (W)	0,30 bar	47.400 m ³ /h	18,6 m ³ /h	R407C	2x 23,7 kg / 25,0 kg	78 dB(A) / 70 dB(A)

*6 – cooling water inlet pressure min 2 bar (g), max. 10 bar (g), cooling water inlet temperature 30°C
cooling water pressostatic valve for use of cooling water temperature < 30°C is standard scope of supply

*7 – The user is committed to keep records of the refrigerant unit if the refrigerant filling is > 3kg (DIN EN378-4.3.1, EG-regulation 842/2006)

Product Data Sheet

Refrigeration Dryer DFLO...

Specifications subject to change without notice

Date 09.02.2023

Latest version see www.fstweb.de

Product specific electrical data

Model	Electrical connection	Installed Power* ⁸	Power consumption* ⁹	Max. current* ⁸	Recommended fuse* ⁸	Protection class	
DFLO 2.4	230V / 50Hz / 1Ph	0,17 kW	0,12 kW	1,0 A	10 A	IP 42	
DFLO 5.4		0,22 kW	0,18 kW	1,3 A	10 A		
DFLO 7.2		0,27 kW	0,20 kW	1,6 A	10 A		
DFLO 10.8		0,66 kW	0,41 kW	3,5 A	10 A		
DFLO 14.4		0,66 kW	0,41 kW	3,5 A	10 A		
DFLO 18		0,80 kW	0,61 kW	4,75 A	10 A		
DFLO 22.5		0,84 kW	0,60 kW	2,7 A	10 A		
DFLO 26		1,28 kW	0,60 kW	3,8 A	10 A		
DFLO 36		1,73 kW	0,90 kW	3,8 A	10 A		
DFLO 48		1,73 kW	1,24 kW	6,0 A	10 A		
DFLO 66 (W)		1,7 kW	1,3 kW	8,4 A	10 A		
DFLO 78 (W)	400V (± 10%) 50Hz / 3Ph	3,5 kW	1,9 kW	5,5 A	10 A		
DFLO 100 (W)		3,5 kW	1,9 kW	5,5 A	10 A		
DFLO 150 (W)		4,8 kW	2,8 kW	8,9 A	10 A		
DFLO 180 (W)		4,8 kW	2,8 kW	8,9 A	10 A		
DFLO 225 (W)		5,3 kW	3,5 kW	8,8 A	10 A		
DFLO 270 (W)		7,5 kW	5,1 kW	12,5 A	16 A		
DFLO 360 (W)		10 kW	6,3 kW	16,9 A	50 A		
DFLO 420 (W)		11,5 kW	7,3 kW	19,6 A	50 A		
DFLO 530 (W)		15 kW	9,5 kW	24,9 A	50 A		
DFLO 600 (W)		460V (± 10%) 60Hz / 3Ph on request	15 kW	9,5 kW	24,9 A		50 A
DFLO 680 (W)			17,5 kW	11 kW	29,3 A		50 A
DFLO 880 (W)	24 kW		15 kW	38,5 A	50 A		
DFLO 1000 (W)	24 kW		15 kW	38,5 A	50 A		
DFLO 1200 (W)	29 kW		18 kW	47,19 A	50 A		
DFLO 1360 (W)	35 kW		22 kW	54,0 A	63 A		
DFLO 1760 (W)	2x 24 kW		2x 15 kW	2x 38,2 A	2x 50 A		
DFLO 2000 (W)	2x 29 kW		2x 18 kW	2x 47,1 A	2x 50 A		
DFLO 2400 (W)	2x 35 kW	2x 22 kW	2x 55,0 A	2x 63 A			

*⁸ – for 400 V / 50 Hz systems (data for 460 V / 60 Hz on request)

*⁹ – at full load (nom. volume flow rate at 20°C/1 bar(a) at 7 bar(g), medium 35°C, cooling air 25°C, pressure dew point +3°C)

Materials

Component	Material
Heat exchanger	Aluminium
Pipes	Refrigerant circuit: Cu; Compressed air collecting pipe: galvanic coated C-steel
Housing	Steel sheet, powder-coated

Product Data Sheet

Refrigeration Dryer DFLO...



Specifications subject to change without notice

Date 09.02.2023

Latest version see www.fstweb.de

Connections, dimensions and weight

Model	Connection	Height	Width	Depth	Connection cooling water	Weight
						aircooled / watercooled
DFLO 2.4	G 3/8"	404 mm	30 mm	360 mm	---	18 kg / ---
DFLO 5.4	G 1/2"	435 mm	370 mm	433 mm	---	26 kg / ---
DFLO 7.2	G 1/2"	435 mm	370 mm	433 mm	---	26 kg / ---
DFLO 10.8	G 3/4"	555 mm	420 mm	515 mm	---	33 kg / ---
DFLO 14.4	G 3/4"	555 mm	420 mm	515 mm	---	34 kg / ---
DFLO 18	G 3/4"	555 mm	420 mm	515 mm	---	43 kg / ---
DFLO 22.4	G 1"	614 mm	485 mm	595 mm	---	62 kg / ---
DFLO 26	G 1"	614 mm	485 mm	595 mm	---	64 kg / ---
DFLO 36	G 1 1/2"	980 mm	500 mm	679 mm	---	87 kg / ---
DFLO 48	G 1 1/2"	980 mm	500 mm	679 mm	---	110 kg / ---
DFLO 66 (W)	G 2"	1360 mm	779 mm	720 mm	3/4"	120 kg / 130 kg
DFLO 78 (W)	G 2"	1360 mm	779 mm	720 mm	3/4"	130 kg / 140 kg
DFLO 100 (W)	G 2"	1360 mm	779 mm	720 mm	3/4"	150 kg / 160 kg
DFLO 150 (W)	G 3"	1539 mm	806 mm	1012 mm	3/4"	234 kg / 240 kg
DFLO 180 (W)	G 3"	1539 mm	806 mm	1012 mm	3/4"	234 kg / 270 kg
DFLO 225 (W)	G 3"	1539 mm	806 mm	1012 mm	1 1/2"	260 kg / 300 kg
DFLO 270 (W)	DN 100	1555 mm	905 mm	1390 mm	1 1/2"	330 kg / 330 kg
DFLO 360 (W)	DN 125	1555 mm	1510 mm	1500 mm	1 1/2"	420 kg / 420 kg
DFLO 420 (W)	DN 125	1555 mm	1510 mm	1500 mm	1 1/2"	520 kg / 520 kg
DFLO 530 (W)	DN 150	1555 mm	1510 mm	1500 mm	1 1/2"	620 kg / 620 kg
DFLO 600 (W)	DN 150	1555 mm	1510 mm	1500 mm	1 1/2"	720 kg / 720 kg
DFLO 680 (W)	DN 150	1555 mm	1510 mm	1500 mm	1 1/2"	735 kg / 745 kg
DFLO 880 (W)	DN 150	1570 mm	2270 mm	1500 mm	2"	1080 kg / 1095 kg
DFLO 1000 (W)	DN 200	1570 mm	2270 mm	1590 mm	2"	1150 kg / 1165 kg
DFLO 1200 (W)	DN 200	1565 mm	2270 mm	1590 mm	2"	1230 kg / 1245 kg
DFLO 1360 (W)	DN 200	1565 mm	3025 mm	1590 mm	2"	1350 kg / 1380 kg
DFLO 1760 (W)	2x DN 200	1570 mm	4535 mm	1500 mm	2x 2"	2160 kg / 2190 kg
DFLO 2000 (W)	2x DN 200	1570 mm	4535 mm	1590 mm	2x 2"	2300 kg / 2330 kg
DFLO 2400 (W)	2x DN 200	1565 mm	4535 mm	1590 mm	2x 2"	2460 kg / 2490 kg

Product Data Sheet

Refrigeration Dryer DFLO...



Specifications subject to change without notice Date 09.02.2023 Latest version see www.fstweb.de

Classification according to Pressure Equipment Directive 2014/68/EU for group 2 fluids

Model	Number of cooler / Volume	Category
DFLO 2.4	0,3 l	Art. 4; Absatz 3
DFLO 5.4	1,6 l	Art. 4; Absatz 3
DFLO 7.2	1,6 l	Art. 4; Absatz 3
DFLO 10.8	2,2 l	Art. 4; Absatz 3
DFLO 14.4	2,6 l	Art. 4; Absatz 3
DFLO 18	3,1 l	Art. 4; Absatz 3
DFLO 22.4	3,7 l	I
DFLO 26	3,7 l	I
DFLO 36	6,8 l	I
DFLO 48	8,9 l	I
DFLO 66 (W)	12,4 l	I
DFLO 78 (W)	12,4 l	I
DFLO 100 (W)	15,3 l	II
DFLO 130 (W)	2 x 12,4 l	II
DFLO 170 (W)	2 x 12,4 l	II
DFLO 220 (W)	2 x 15,3 l	II
DFLO 270 (W)	3 x 12,4 l	II
DFLO 360 (W)	4 x 12,4 l	II
DFLO 420 (W)	4 x 15,3 l	II
DFLO 530 (W)	5 x 15,3 l	II
DFLO 600 (W)	6 x 15,3 l	II
DFLO 680 (W)	6 x 15,3 l	II
DFLO 880 (W)	8 x 15,3 l	II
DFLO 1000 (W)	10 x 15,3 l	II
DFLO 1200 (W)	12 x 15,3 l	II
DFLO 1360 (W)	12 x 15,3 l	II
DFLO 1760 (W)	2 x (8 x 15,3 l)	II
DFLO 2000 (W)	2 x (10 x 15,3 l)	II
DFLO 2400 (W)	2 x (12 x 15,3 l)	II

Other Directives

	Model
<p>CE marking is according to the Machinery Directive 2006/42/EC Declaration of conformity for functional test acc ISO/IEC 17050-1</p> <p>EMC Standard acc 2004/108/CE, Emittet interface tested acc. EN 61000-3-2:2006-04, EN 61000-3-3:2008, Interference resistance acc: EN 61000-6-2:2005</p> <p>EC directive on low voltage equipment 2006/42/CE</p>	All Models

Product Data Sheet

Refrigeration Dryer DFLO...

Specifications subject to change without notice
Dimension sheet DFLO 2.4-48

Date 09.02.2023

Latest version see www.fstweb.de

DFLO 2.4 – 7.2

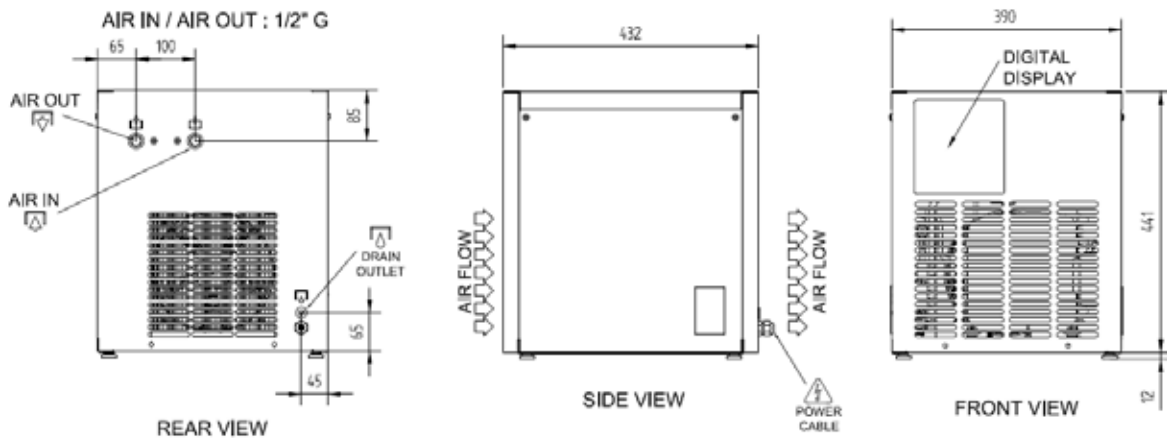

DFLO 10.8 - 18

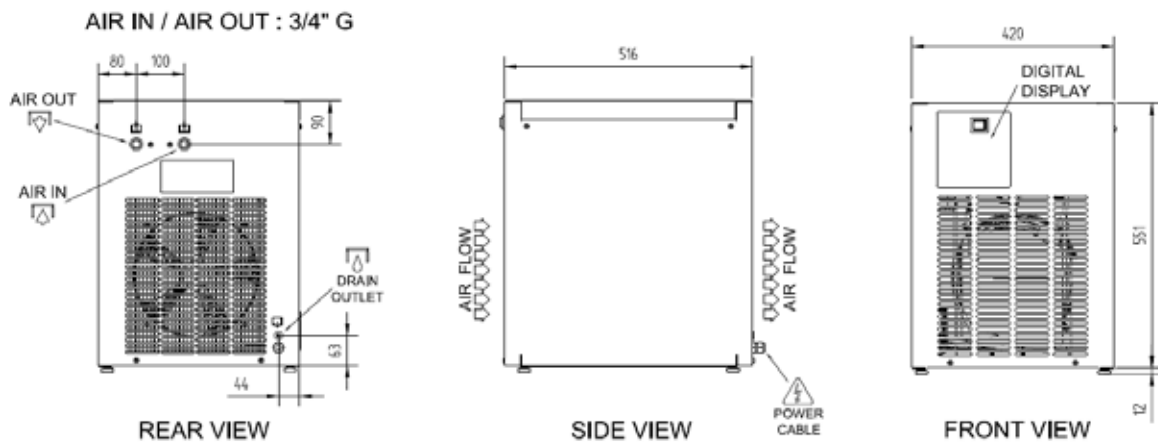

DFLO 22.4 - 26

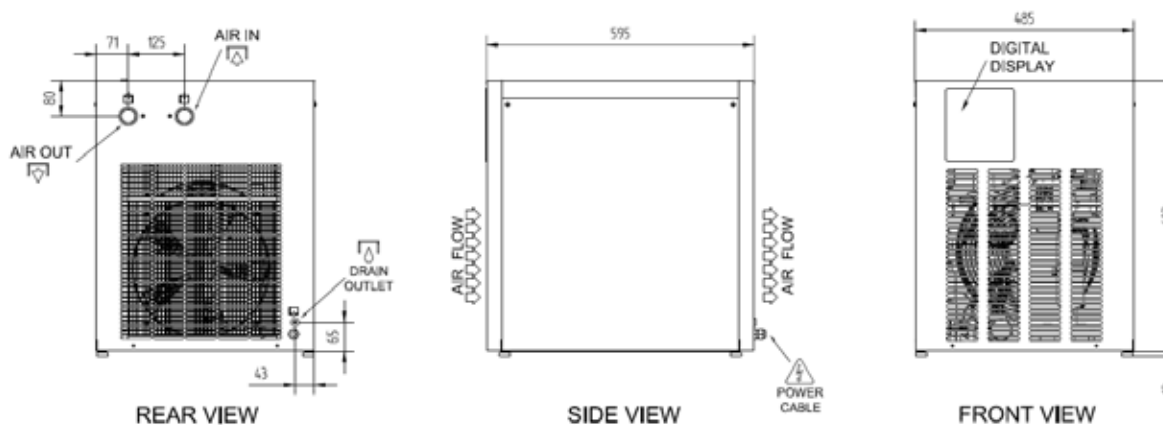

DFLO 36 – 48

Product Data Sheet

Refrigeration Dryer DFLO...



Specifications subject to change without notice

Date 09.02.2023

Latest version see www.fstweb.de

AIR IN / AIR OUT : 1"1/2 G

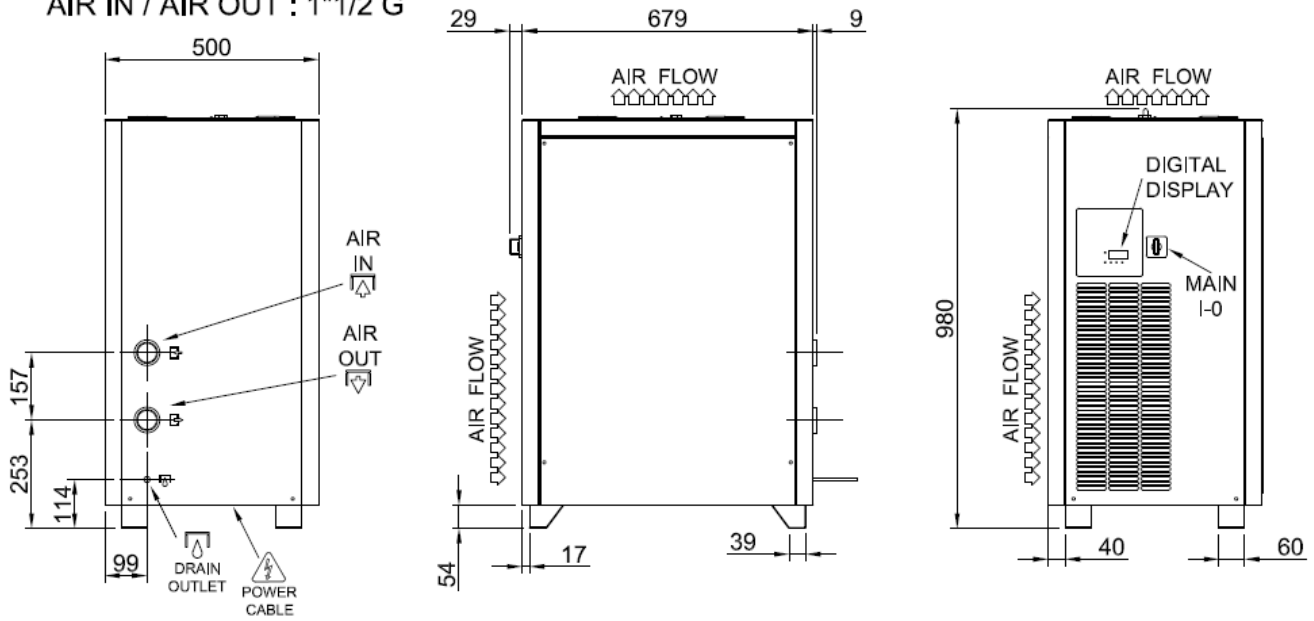

Dimension sheet DFLO 66-270

DFLO 66 - 100

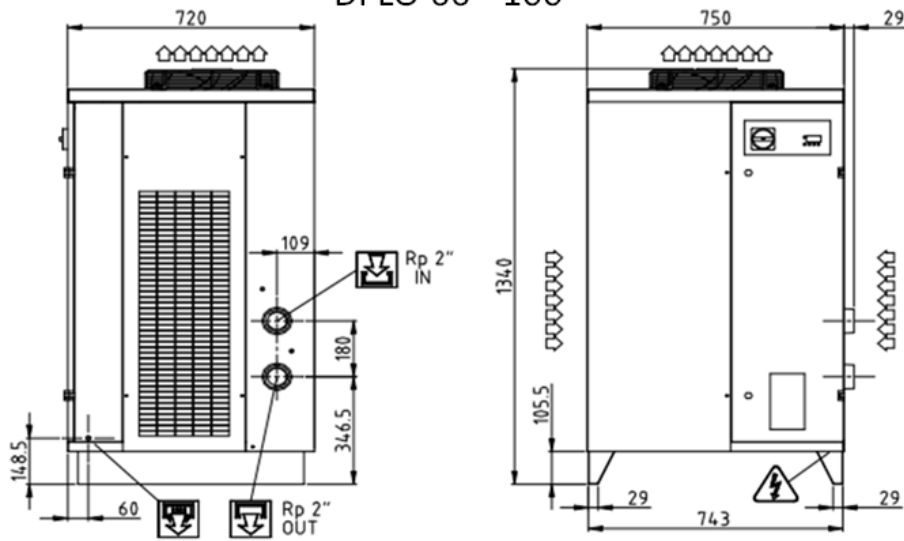

Product Data Sheet

Refrigeration Dryer DFLO...

Specifications subject to change without notice

Date 09.02.2023

Latest version see www.fstweb.de

DFLO 150 - 225

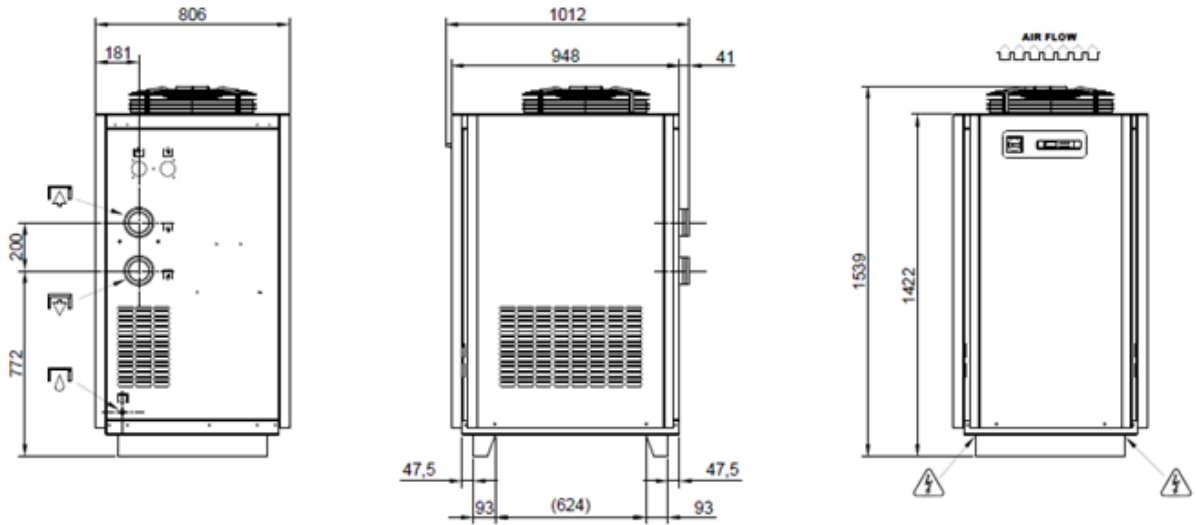

DFLO 270

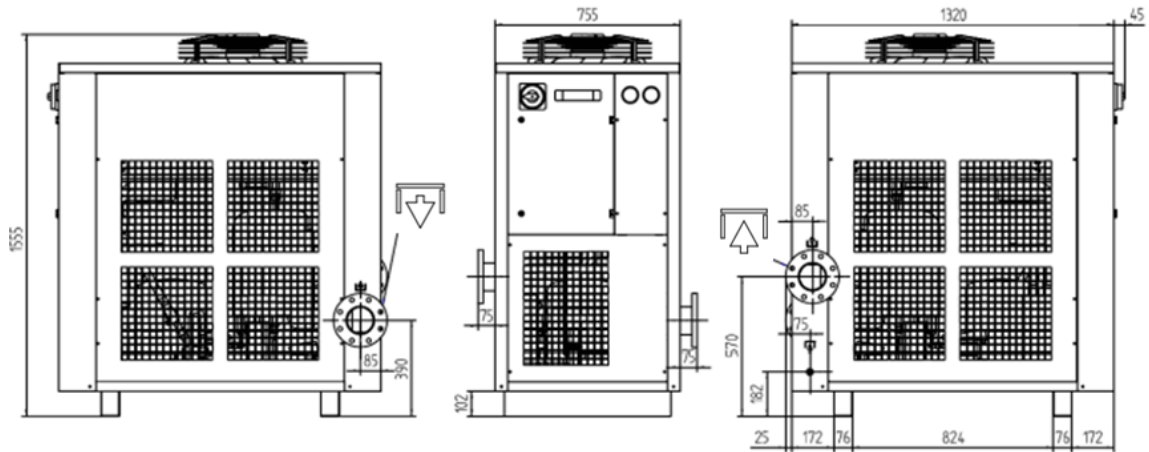

Dimension sheet DFLO 360-1360

DFLO 360 – 420 – 530 – 600 - 680

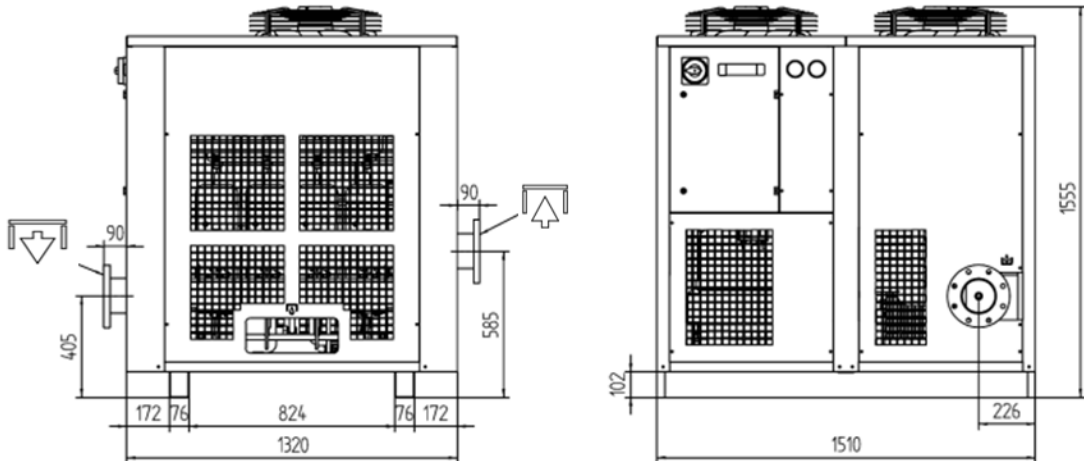

Product Data Sheet

Refrigeration Dryer DFLO...

Specifications subject to change without notice

Date 09.02.2023

Latest version see www.fstweb.de

DFLO 880 – 1000 - 1200

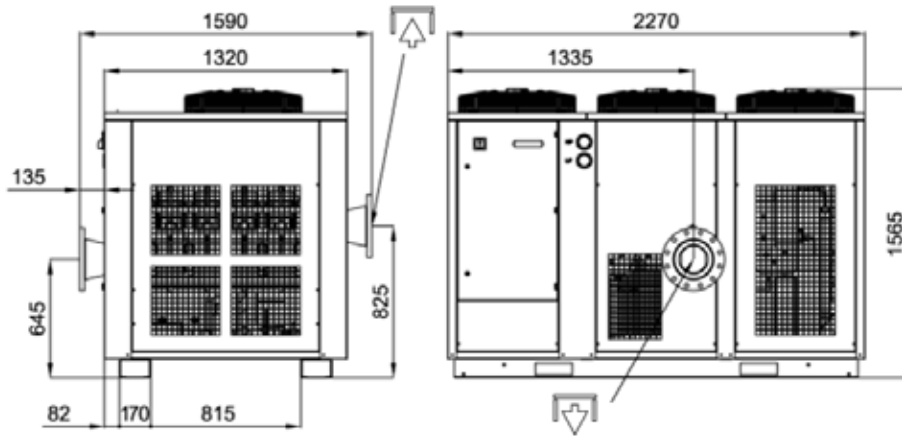

DFLO 1360

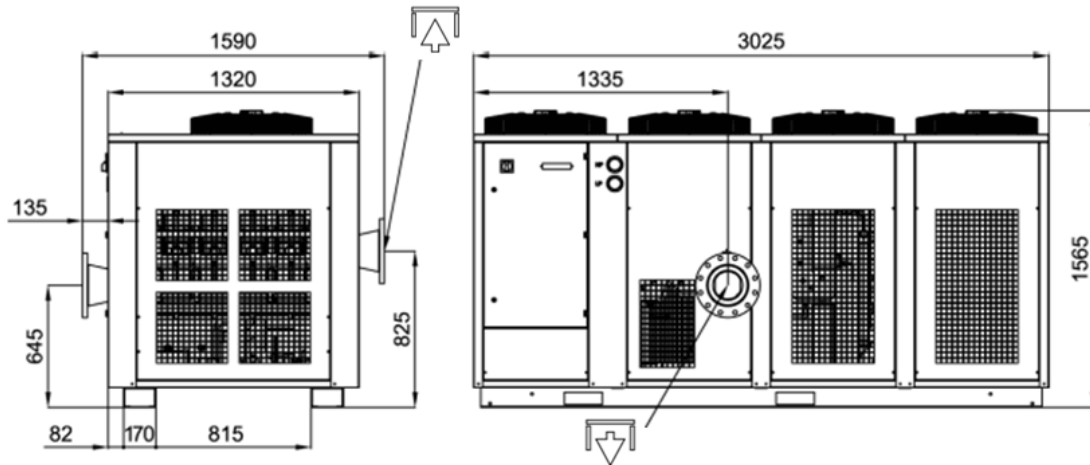

Dimension sheet DFLO 2400

DFLO 2400

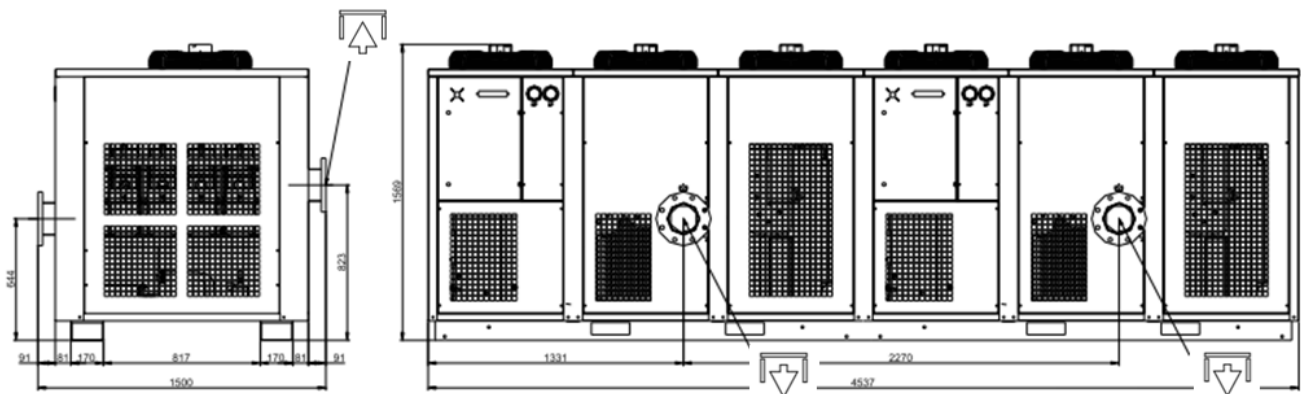

Product Data Sheet

Refrigeration Dryer DFLO...



Specifications subject to change without notice Date 09.02.2023 Latest version see www.fstweb.de

Model	DFLO 270	DFLO 360	DFLO 420	DFLO 530	DFLO 600	DFLO 680	DFLO 880	DFLO 1000	DFLO 1200	DFLO 1360	DFLO 1760	DFLO 2000	DFLO 2400	
Number of evaporator	3	4		5	6		4 + 4	5 + 5	6 + 6	6 + 6	2x 4 + 4	2x 5 + 5	2x 6 + 6	
Number of condenser	1	2					3			4	6			
Number of condensate drain	1		2								4			

Product Data Sheet

Refrigeration Dryer DFLO...

Specifications subject to change without notice

Date 09.02.2023

Latest version see www.fstweb.de

Flow diagramm (PID) DFLO 66

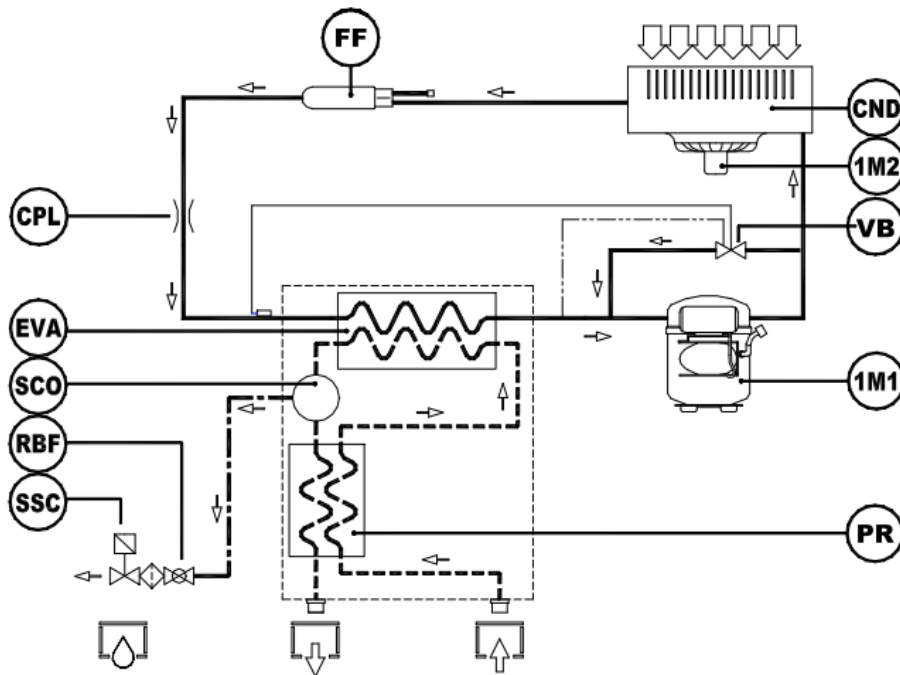

Flow diagramm (PID) DFLO 78–100

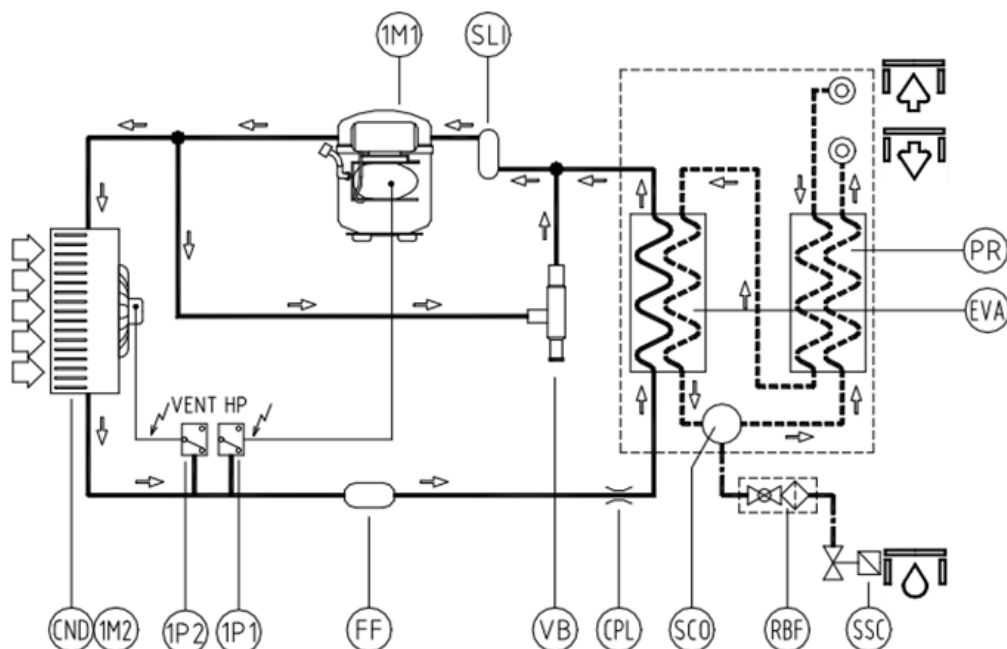

Product Data Sheet

Refrigeration Dryer DFLO...

Specifications subject to change without notice

Date 09.02.2023

Latest version see www.fstweb.de

Flow diagramm (PID) DFLO 130-220

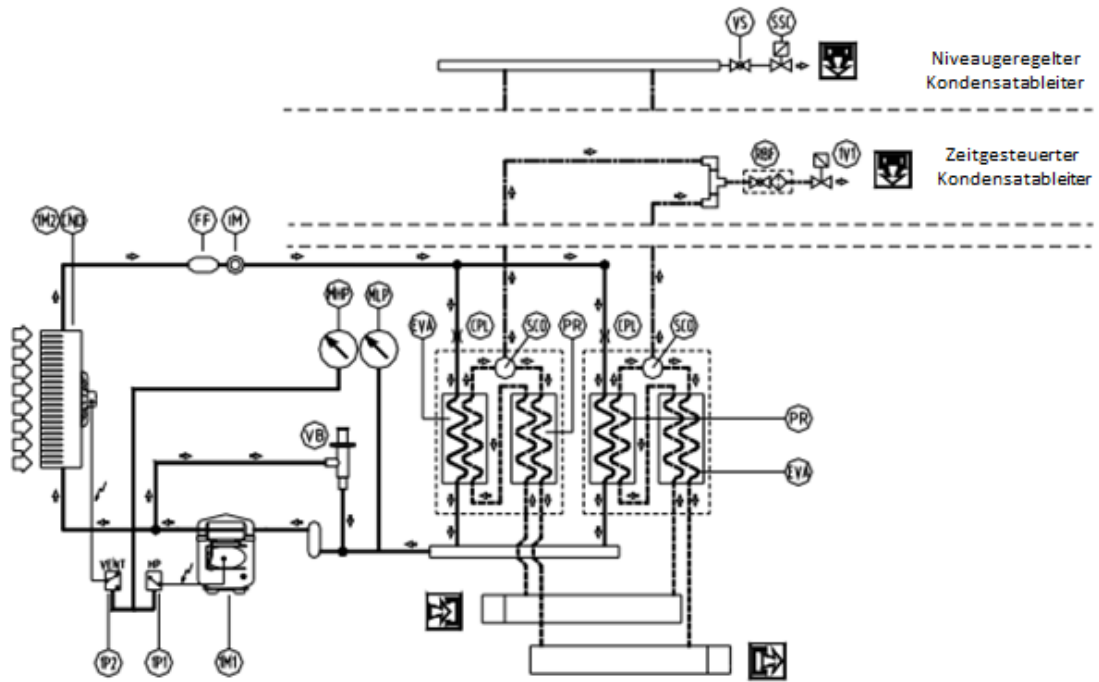

Flow diagramm (PID) DFLO 270-1370

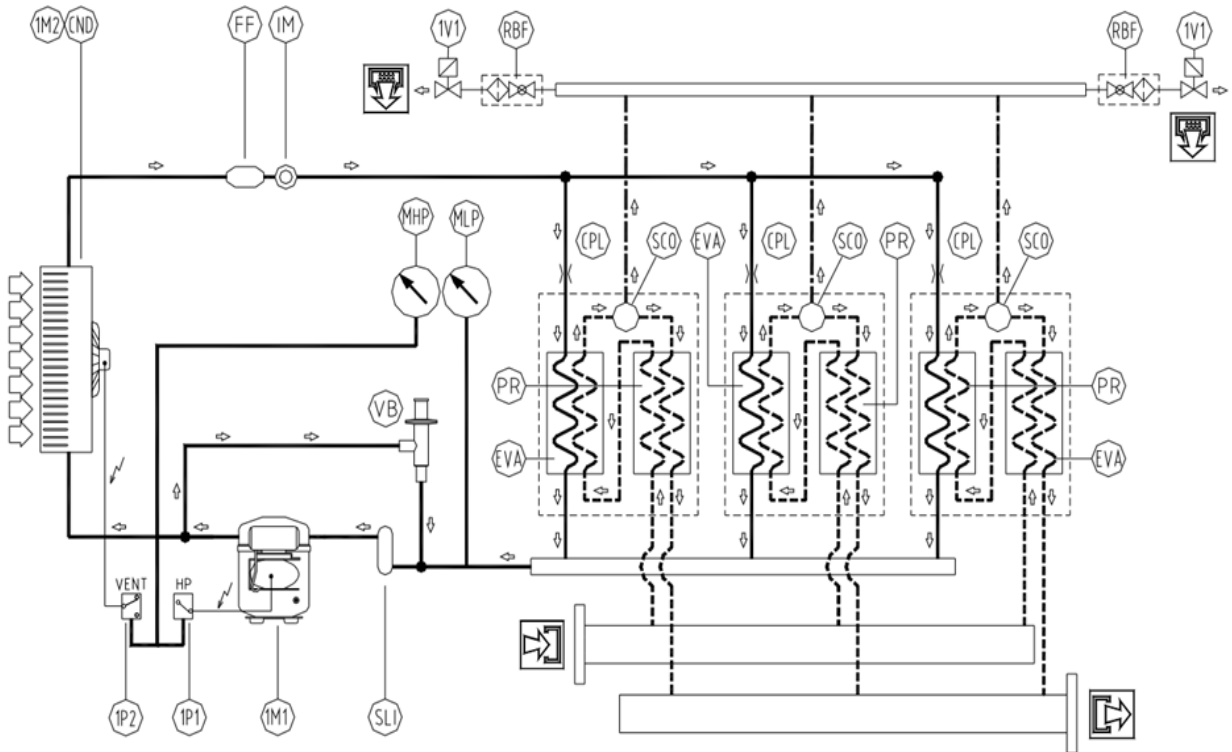

Product Data Sheet

Refrigeration Dryer DFLO...



Specifications subject to change without notice

Date 09.02.2023

Latest version see www.fstweb.de

Legend to Flow diagramm (PID)

1M1	Hermetic refrigerant compressor
1M2	Fan motor
1P1	High pressure Switch (from DFLO 78)
1P2	Fan pressure Switch (not for watercooled version)
1V1	Condensate drain
CND	Condenser Refrigerant/ air heat exchanger (at watercooled version Refrigerant /Water heat exchanger)
CPL	Capillary tube
EVA	Evaporator (Refrigerant/ Compressed air heat exchanger)
FF	Filter dryer
IM	Sight glass
MHP	Refrigerant High pressure Manometer
MLP	Refrigerant Low pressure Manometer
PR	Air/ air heat exchanger
RBF	Ball valve with strainer
SCO	Condensate separator

Product Data Sheet

Refrigeration Dryer DFLO...



Specifications subject to change without notice

Date 09.02.2023

Latest version see www.fstweb.de

Notes

Product Data Sheet

Refrigeration Dryer DFLO...



Specifications subject to change without notice

Date 09.02.2023

Latest version see www.fstweb.de

Notes

Product Data Sheet

Refrigeration Dryer DFLO...

Accessories



The DA-CM1-230 switch-over control system enables the control of two redundant compressed air dryers in a compressed air system. The two dryers can be operated alternately while switching-over automatically. All dryers, provided with a «remote start/stop contact» or a «compressor synchronisation contact», can be directly connected to the switch-over control system without the need for any further modifications. The DA-CM1-230 also controls all required shut-off valves (no scope of supply) to open or close the compressed air line to a dryer (e.g. solenoid valves or valves with actuating drive for 230V AC supply voltage). Furthermore, additional input signals can be hooked up to the common alarm message of each dryer. Beside the power supply the DA-CM1-230 provides alarm inputs for condensate drains, differential pressure gauges, etc. for each dryer.

The GSM Module DA-ETR-107 is an easy to install extension for all dryers with alarm contact. In case of an alarm a SMS message is send to up to 6 different recipients or, if supported by the provider, an email message. Within the message, the dryer type and serial number is transferred, if required.

The programming can be done with a usual mobile phone, protected by the PIN code of the SIM card (no scope of supply) applied to the GSM module. The DA-ETR-107 is operated with 5-32V DC supply voltage. An internal battery ensures operation of up to 120 hours in case of loss of the supply voltage. The GSM module has an integrated antenna while an external antenna can be connected in the case of low signal levels.



The Start-up device (minimum pressure valve) DA-VPM-... protects the dryer from overload due to high flow velocities during pressure build-up of the compressed air system. For connection size G ½ to G 2½ spring loaded angle valves are offered (DA-VPM-B../16), providing an opening pressure of 3-5 bar (standard 3.5 bar). For connection size DN80 to DN250 butterfly valves with pneumatic actuator are offered (DA-VPM-F../11), directly operated by the working pressure while opening at 3 bar (full cross-section at 4 bar). Special versions with adjustable opening pressure or working pressures of up to 450 bar are available on request.



Differential pressure gauges FAD01C with potential free alarm contact allow to hook up the differential pressure control of the pre- and after-filter to the common alarm message of each dryer. In order to avoid a false error report due to start-up conditions or short-time peaks, an alarm delay can be set in the dryer control unit. The alarm message then will just be generated, if a too high differential pressure was indicated during the entire delay time interval.

... and many more. Please contact us.