

# Product Data Sheet

## Adsorption Dryer DPS 10-100 (A)

Version: 1.8.0

Author: Tassilo Tappe

Date:13.07.2018

### Field of application

Adsorption dryers of the DPS series are designed for drying compressed air and nitrogen to pressure dew points of  $-25^{\circ}\text{C}$  to  $-70^{\circ}\text{C}$  (depending on the design) at operating pressures of 4 bar to 16 bar. On request design pressures up to 63 bar are possible.

### Function

For drying the compressed air, i.e. "adsorption", the compressed air flow is led through a vessel filled with desiccant. The desiccant extracts moisture from the compressed air and stores it in its structure until the desiccant is saturated with moisture. The saturated desiccant then has to be regenerated, i.e. the moisture stored in the structure has to be "removed" before the desiccant can be used for drying again. Continuous operation of an adsorption dryer therefore requires two vessels that are operated alternately. One vessel is used for drying the compressed air (adsorption) and the other vessel for regenerating the desiccant. For the DPS series the change interval between adsorption and regeneration is 5 minutes at nominal conditions. For the DPS series a certain quantity of dried compressed air is drawn off at the dryer outlet (*approx. 15% of the nominal volume flow rate at nominal conditions*). This amount of compressed air is expanded to atmospheric pressure and is led through the vessel to regenerate the desiccant. The dried, decompressed air is extremely moisture-subsaturated and thus extracts the moisture stored in the desiccant and discharges it to the atmosphere via a silencer (heatless regeneration).



# Product Data Sheet

## Adsorption Dryer DPS 10-100 (A)

### Features

The desiccant has a high drying capacity for moisture and a long service life of several years. This ensures permanently low and stable pressure dew points.

The valves and flow paths required for vessel chamber switch-over are completely installed in valve blocks. This integrated design eliminates the need for time-consuming piping installation and minimises the leak potential. Air flow cross-section sizes above average minimise the pressure loss.

The solenoid valve combination consists of 4 pilot-controlled diaphragm valves. Thanks to the individual control option for each valve, overlapping switch-over and a defined flow path is ensured at any time. The non-return valve combination consisting of 2 non-return valves is also installed in a leak-free aluminium valve block. A silencer is used for effective reduction of the expansion noise.

The valves of the DPS series are controlled by means of a type "C1" processor control system with a 2-line clear text display and 3 operating keys. The control system is installed in a plastic housing with IP65 protection. The clear text display is used for direct and easy-to-understand indication of the operating state, errors, runtimes, service messages etc. If a pressure dew point sensor (option H) is connected, the current pressure dew point of the compressed air is also directly shown on the display and provided as a 4-20 mA signal. The pressure dew point measurement (option H) allows for dew-point dependent operation of the dryer. Depending on the load of the dryer, the adsorption cycle may be extended, i.e. the switch-over frequency is adapted to the operating situation. This minimise the regeneration air consumption and thus the energy costs are minimised.

In addition, the control system provides a compressor synchronising contact. It is used for synchronous operation of the dryer and a compressor which additionally reduces the regeneration air consumption. This function can also be used in conjunction with dew point-dependent operation. If a differential pressure monitoring system with alarm contact is fitted to the prefilter and afterfilter (option), the alarm contacts can be connected to the control system, displayed and processed.



As standard, the dryer is provided with a prefilter (fine filter) which prevents solid and liquid contaminants from entering the dryer. This increases the service life of the dryer. An afterfilter (general purpose filter) is also provided as standard. It is used to prevent desiccant dust from entering the downstream system. The filters are directly flanged to the upper valve block. Therefore, piping material is not required.

The dryers comply with the requirements of the Pressure Equipment Directive 2014/68/EU, and have the CE marking of this European directive.

# Product Data Sheet

## Adsorption Dryer DPS 10-100 (A)

Specifications subject to change without notice

Date 13.07.2018

Latest version see [www.fstweb.de](http://www.fstweb.de)

### Basic data

Model	Nominal volume flow (VN) <sup>*1</sup>	Min./Max. allowable operating pressure	Min./Max. allowable operating temperature
DPS 10 (A)	110 m <sup>3</sup> /h	4 - 16 bar (higher design pressures up to 63 bar on request )	+2°C - +60°C
DPS 15 (A)	150 m <sup>3</sup> /h		
DPS 20 (A)	200 m <sup>3</sup> /h		
DPS 25 (A)	260 m <sup>3</sup> /h		
DPS 30 (A)	320 m <sup>3</sup> /h		
DPS 40 (A)	410 m <sup>3</sup> /h		
DPS 60 (A)	590 m <sup>3</sup> /h		
DPS 80 (A)	770 m <sup>3</sup> /h		
DPS 100 (A)	1,000 m <sup>3</sup> /h		

\*1 - referred to 1 bar(a) and 20°C at 7 bar operating pressure, inlet temperature 35°C and pressure dew point at outlet -40°C

### Purity classes according to ISO 8573-1

Contamination	DPS..	DPS..A
Solid particles <sup>*2</sup>	(Class 2)	
Water content <sup>*2</sup>	Class 1-3 <sup>*3</sup>	
Total oil content <sup>*2</sup>	Class 1 <sup>*4</sup>	Class 0-1

\*2 - typical result, on the assumption that the suitable inlet concentrations and operating and marginal conditions are given

\*3 - depending on the design

\*4 - the oil vapour content is not taken into account, it may reduce the purity class

### Volume flow conversion factors

#### «F1» - Pressure in bar (g)

4 <sup>*5</sup>	5	6	7	8	9	10	11	12	13	14	15	16
0.63	0.75	0.88	1.00	1.13	1.25	1.38	1.50	1.63	1.75	1.88	2.00	2.13

\*5 - in the event of operating pressures below 5 bar, an external instrument air supply must be provided

#### «F2» - Inlet temperature in °C

25	30	35	40	45	50	55	60
1.00	1.00	1.00	0.97	0.87	0.80	0.64	0.51

### Calculation of the converted volume flow

Converted volume flow VK	Nominal required volume flow VN <sub>min</sub>
$VK = VN \times F1 \times F2$	$VN_{min} = VK / F1 / F2$

VK : Converted volume flow calculated for the operating conditions

VN<sub>min</sub>: Nominal required volume flow calculated for the operating conditions, based on the volume flow at operating conditions

# Product Data Sheet

## Adsorption Dryer DPS 10-100 (A)

### Maintenance rules

	Maintenance interval and maintenance activities
All Models	<ul style="list-style-type: none"> <li>■ Once a week :               <ul style="list-style-type: none"> <li>- Check differential pressure on the prefilter and afterfilter</li> <li>- Check function of the condensate drain on the prefilter</li> </ul> </li> <li>■ Every 12 months :               <ul style="list-style-type: none"> <li>- Replace filter elements on prefilter and afterfilter</li> <li>- Check expansion silencer, clean or replace, if required</li> <li>- Replace activated carbon and oil indicator tube (type DPS..A) *7</li> <li>- Calibrate dew point sensor (option H) (interchange principle possible)</li> </ul> </li> <li>■ Every 24 months:               <ul style="list-style-type: none"> <li>- Replace non-return valves and solenoid valves</li> </ul> </li> <li>■ Every 48 months:               <ul style="list-style-type: none"> <li>- Replace desiccant, sleeve cylinder and seals*6 *7</li> </ul> </li> <li>■ Every 5 /10 years (for DPS 40 – DPS 100)               <ul style="list-style-type: none"> <li>- Pressure vessel inspection acc. to Ordinance on Industrial Safety and Health of September 27th, 2002 (BGBl. I p. 3777) §15,</li> <li>- Inside check every 5 years, carried out by an authorised inspection agency</li> <li>- Strength test (hydrostatic) every 10 years, carried out by an authorised inspection agency, see page 5</li> </ul> </li> </ul>

\*6 – The regular service life of the desiccant is 3 - 5 years, however, it is very much depending on the contamination level of the incoming compressed air and the operating temperature. In order to achieve the specified service life of the desiccant, it is vital to exchange the filter elements as described above.

\*7 – The desiccant and the activated carbon must be disposed of according to the European waste code. A possible oil contamination must be taken into account.

### Product specific data

Specification	
Pressure dew points	-25°C / -40°C / -70°C
Electrical connection	230V 50/60 Hz, alternative 115V 50/60Hz or 24V DC
Power consumption	< 50 Watt
Protection Class	IP 65 (Nema 4)
Valve switching power (for each valve)	20 Watt

### Materials

Component	
Vessel and supports	Steel (P265GH, ST37.0, St35.8)
Coating	Outside : sand blasted SA2,5 (ISO8501) ; 1-component primer on alkyd resin base ; dry thickness approx 40 µm (e.g. DuPont PercoTop 021, or similar product) 2-component acrylic resin paint ; dry thickness approx 40 µm (e.g. DuPont PercoTop 9600, or similar product)
Desiccant support screen	Stainless steel 304
Pipe connections (fittings)	Steel, galvanized
Valve body	Aluminium
Valve seats	Brass (Ms58), reinforced plastic
Sealing materials	HNBR
Screws	5.6 steel, zinc-plated (on valve blocks 8.8 stainless 304)
Desiccant filling	80% Molecular sieve 4A und 20% Silica gel
Mounted prefilter and afterfilter	See product data sheets for filter housing and filter elements

# Product Data Sheet

## Adsorption Dryer DPS 10-100 (A)

Specifications subject to change without notice

Date 13.07.2018

Latest version see [www.fstweb.de](http://www.fstweb.de)

### Connections, dimensions and weight (including prefilter and afterfilter)

#### DPS

Model	Connection	Height	Width	Depth	Weight	Prefilter type	Afterfilter type
DPS 10	G 1	1460 mm	675 mm	515 mm	126 kg	FCA110XNDF	FCA110ZNDM
DPS 15	G 1	1700 mm	675 mm	515 mm	142 kg	FCA110XNDF	FCA110ZNDM
DPS 20	G 1	1710 mm	675 mm	515 mm	180 kg	FCA110XNDF	FCA110ZNDM
DPS 25	G 1	1735 mm	675 mm	515 mm	220 kg	FCA110XNDF	FCA110ZNDM
DPS 30	G 1 1/2	1825 mm	745 mm	520 mm	255 kg	FCA115XNDF	FCA115ZNDM
DPS 40	G 1 1/2	1840 mm	755 mm	525 mm	275 kg	FCA120XNDF	FCA120ZNDM
DPS 60	G 1 1/2	1870 mm	775 mm	575 mm	355 kg	FCA130XNDF	FCA130ZNDM
DPS 80	G 2	2045 mm	1050 mm	695 mm	470 kg	FCA140XNDF	FCA140ZNDM
DPS 100	G 2	2060 mm	1050 mm	730 mm	560 kg	FCA140XNDF	FCA140ZNDM

#### DPS..A

Model	Connection	Height	Width	Depth	Weight	Prefilter type	Afterfilter type
DPS 10 A	G 1	1460 mm	955 mm	515 mm	173 kg	FCA110XNDF	FCA110ZNDM
DPS 15 A	G 1	1700 mm	955 mm	515 mm	195 kg	FCA110XNDF	FCA110ZNDM
DPS 20 A	G 1	1710 mm	955 mm	515 mm	250 kg	FCA110XNDF	FCA110ZNDM
DPS 25 A	G 1	1735 mm	955 mm	515 mm	300 kg	FCA110XNDF	FCA110ZNDM
DPS 30 A	G 1 1/2	1825 mm	1130 mm	520 mm	350 kg	FCA115XNDF	FCA115ZNDM
DPS 40 A	G 1 1/2	1840 mm	1140 mm	525 mm	395 kg	FCA120XNDF	FCA120ZNDM
DPS 60 A	G 1 1/2	1870 mm	1200 mm	575 mm	525 kg	FCA130XNDF	FCA130ZNDM
DPS 80 A	G 2	2045 mm	1470 mm	695 mm	630 kg	FCA140XNDF	FCA140ZNDM
DPS 100 A	G 2	2060 mm	1520 mm	730 mm	740 kg	FCA140XNDF	FCA140ZNDM

### Classification according to Pressure Equipment Directive 2014/68/EU for group 2 fluids

Model	Volume	Category	Marking
DPS 10 (A)	21 litres	II	CE 0525
DPS 15 (A)	26 litres	II	CE 0525
DPS 20 (A)	34.5 litres	II	CE 0525
DPS 25 (A)	44.5 litres	II	CE 0525
DPS 30 (A)	55.6 litres	II	CE 0525
DPS 40 (A)	71 litres	III	CE 0525
DPS 60 (A)	101 litres	III	CE 0525
DPS 80 (A)	132 litres	III	CE 0525
DPS 100 (A)	175 litres	III	CE 0525

# Product Data Sheet

## Adsorption Dryer DPS 10-100 (A)

Specifications subject to change without notice

Date 13.07.2018

Latest version see [www.fstweb.de](http://www.fstweb.de)

### Other Directives

Model	
All Models	<p>EMC-Standard (inspection scope for control system, solenoid valves and dew point measurement):  <i>Emitted interference acc. : EN 55011:1998 + A1:1999 + A2:2002 (limit value class: B)</i>  <i>EN 61000-3-2:2006-04, EN61000-3-3:2008</i>  <i>Interference resistance acc. : EN 61000-6-2:2005</i></p> <p>Machinery Directive 2006/42/EC is not applicable.</p>

### Flow diagram (PID) for DPS

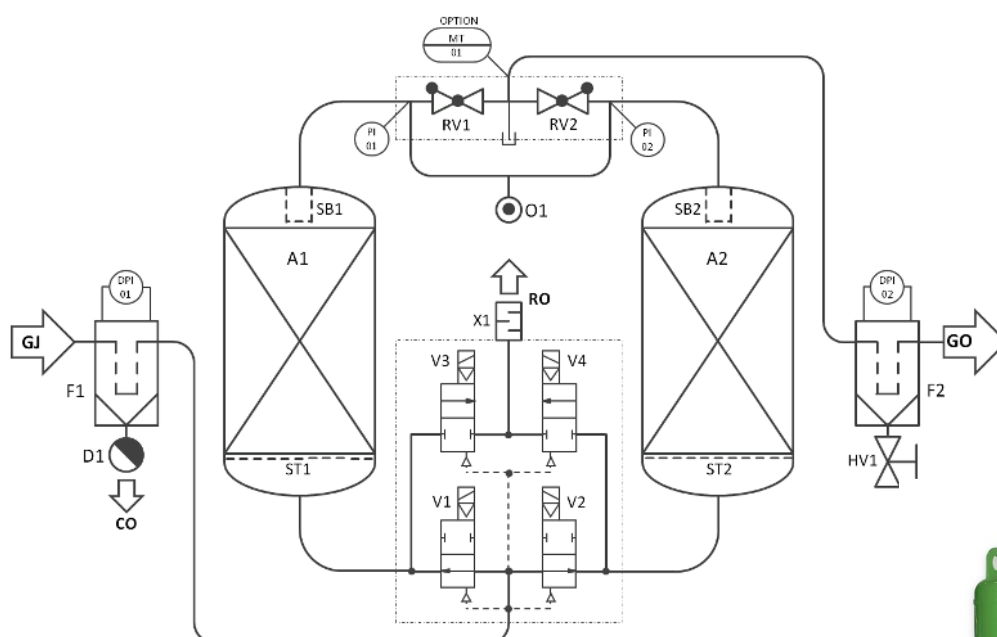

- A** Dryer vessel
- F** Filter
- V** Valve
- HV** Manual valve
- RV** Non return valve
- SB** Sleeve cylinder
- ST** Support screen
- X** Silencer for expansion
- D** Condensate drain
- O** Orifice for regeneration air flow
- PI** Pressure gauge
- DPI** Differential pressure gauge
- MT** Pressure dew point transmitter

- GJ** Gas inlet
- GO** Gas outlet
- RO** Regeneration air outlet
- CO** Condensate outlet



# Product Data Sheet

## Adsorption Dryer DPS 10-100 (A)

Specifications subject to change without notice

Date 13.07.2018

Latest version see [www.fstweb.de](http://www.fstweb.de)

### Flow diagram (PID) for DPS..A

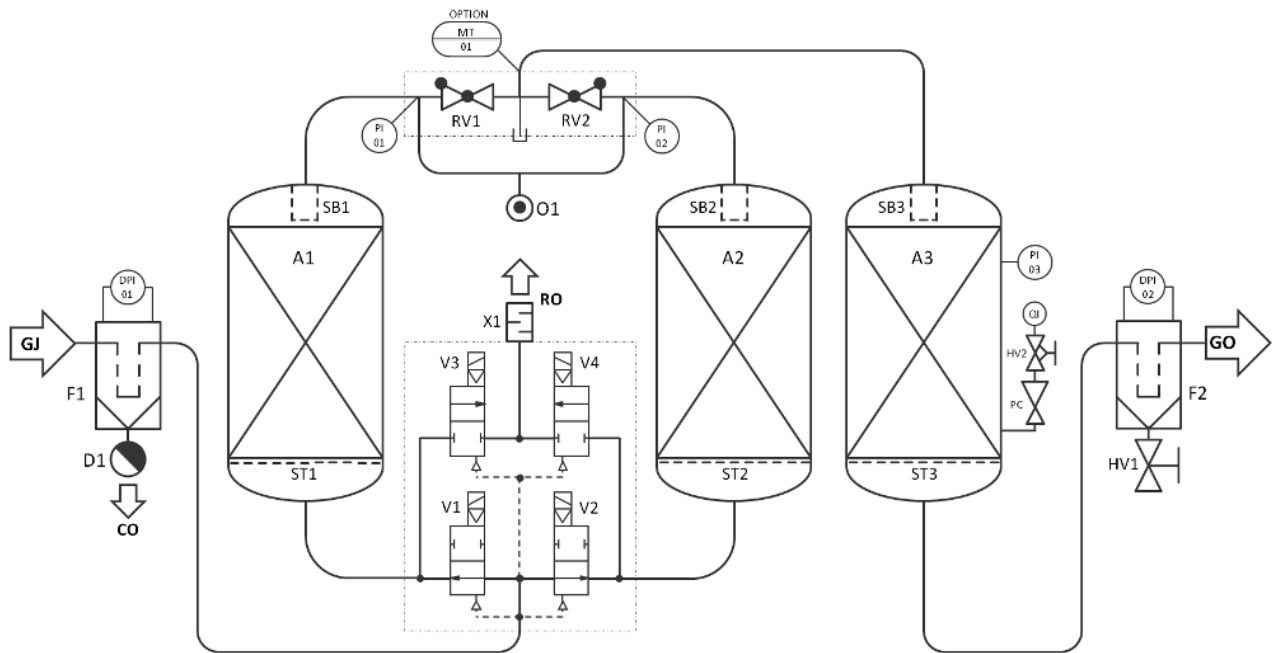

- A** Dryer vessel
- F** Filter
- V** Valve
- HV** Manual valve
- RV** Non return valve
- SB** Sleeve cylinder
- ST** Support screen
- X** Silencer for expansion
- D** Condensate drain
- O** Orifice for regeneration air flow
- PI** Pressure gauge
- DPI** Differential pressure gauge
- QI** Oil-Indicator with throttle valve
- PC** Pressure regulator 7bar[g]
- MT** Pressure dew point transmitter
  
- GJ** Gas inlet
- GO** Gas outlet
- RO** Regeneration air outlet
- CO** Condensate outlet



# Product Data Sheet

## Adsorption Dryer DPS 10-100 (A)

### Accessories



**The DA-CM1-230 switch-over control system** enables the control of two redundant compressed air dryers in a compressed air system. The two dryers can be operated alternately while switching-over automatically. All dryers, provided with a «remote start/stop contact» or a «compressor synchronisation contact», can be directly connected to the switch-over control system without the need for any further modifications. The DA-CM1-230 also controls all required shut-off valves (no scope of supply) to open or close the compressed air line to a dryer (e.g. solenoid valves or valves with actuating drive for 230V AC supply voltage). Furthermore, additional input signals can be hooked up to the common alarm message of each dryer. Beside the power supply the DA-CM1-230 provides alarm inputs for condensate drains, differential pressure gauges, etc. for each dryer.



**The GSM Module DA-ETR-107** is an easy to install extension for all dryers with alarm contact. In case of an alarm a SMS message is send to up to 6 different recipients or, if supported by the provider, an email message. Within the message, the dryer type and serial number is transferred, if required.

The programming can be done with a usual mobile phone, protected by the PIN code of the SIM card (no scope of supply) applied to the GSM module. The DA-ETR-107 is operated with 5-32V DC supply voltage. An internal battery ensures operation of up to 120 hours in case of loss of the supply voltage. The GSM module has an integrated antenna while an external antenna can be connected in the case of low signal levels.



**The Start-up device (minimum pressure valve) DA-VPM-...** protects the dryer from overload due to high flow velocities during pressure build-up of the compressed air system. For connection size G ½ to G 2½ spring loaded angle valves are offered (DA-VPM-B../16), providing an opening pressure of 3-5 bar (standard 3.5 bar). For connection size DN80 to DN250 butterfly valves with pneumatic actuator are offered (DA-VPM-F../11), directly operated by the working pressure while opening at 3 bar (full cross-section at 4 bar). Special versions with adjustable opening pressure or working pressures of up to 450 bar are available on request.



**Differential pressure gauges FAD01C with potential free alarm contact** allow to hook up the differential pressure control of the pre- and after-filter to the common alarm message of each dryer. In order to avoid a false error report due to start-up conditions or short-time peaks, an alarm delay can be set in the dryer control unit. The alarm message then will just be generated, if a too high differential pressure was indicated during the entire delay time interval.

... and many more. Please contact us.